

ORTAL®

Installation and Operation Manual Stand Alone TS Series

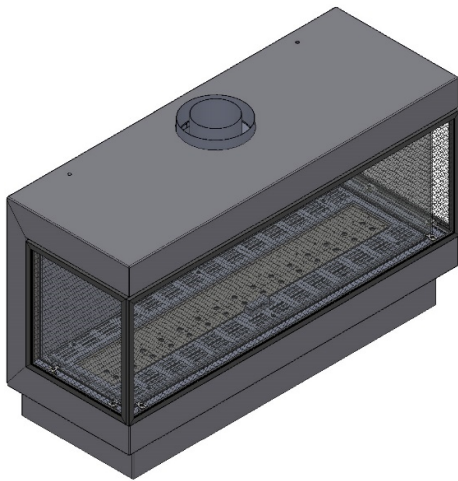
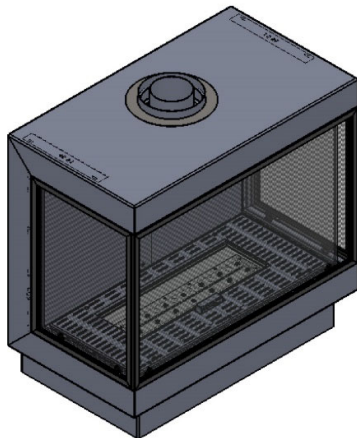
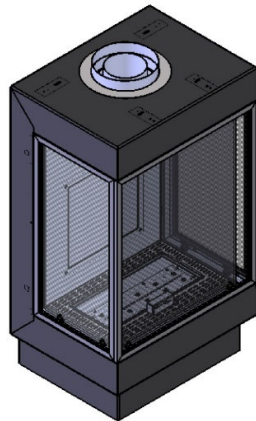

**Manufacturer Update
Serial Number 21818 and Forward**

⚠ WARNING:
FIRE OR EXPLOSION HAZARD
Failure to follow safety warnings exactly could result in serious injury, death, or property damage.

- **DO NOT** store or use gasoline or other flammable vapors and liquids in the vicinity of this or any other appliance.
- **What to do if you smell gas:**
 - **DO NOT** try to light any appliance.
 - **DO NOT** touch any electrical switch. **DO NOT** use any phone in your building.
 - Leave the building immediately.
 - Immediately call your gas supplier from a neighbor's phone. Follow the gas supplier's instructions.
 - If you cannot reach your gas supplier, call the fire department.
- Installation and service must be performed by a qualified installer, service agency, or the gas supplier.

! DANGER



**HOT GLASS WILL
CAUSE BURNS.**

**DO NOT TOUCH GLASS
UNTIL COOLED.**

**NEVER ALLOW CHILDREN
TO TOUCH GLASS.**

A barrier designed to reduce the risk of burns from the hot viewing glass is provided with this appliance and must be installed for the protection of children and other at-risk individuals.



Stand Alone TS Series Fireplaces:

Stand Alone 40 TS

Stand Alone 75 TS (decorative base optional)

Stand Alone 110 TS (decorative base optional)

Safety Information and Warnings



IMPORTANT NOTE: LOCAL CODE

Local codes and regulations that are more stringent than the requirements in this manual take precedence over Ortal requirements.



WARNING: REVIEW ALL WARNINGS

Be sure to review all safety warnings and installation guidelines contained in this manual. Consider installation location, vent configuration, clearances, structural requirements, framing and finish materials, and local codes. ALL warnings and instructions apply to all products manufactured and distributed by Ortal.



WARNING: DO NOT OPERATE FIREPLACE IF:

The glass is NOT properly secured in place; Connection points are not sealed (for fireplaces with glass-to-glass connections); Glass is cracked; You smell gas; Any part of the fireplace has been under water; You have any doubt about safe operation of the fireplace. Immediately call a qualified, professional service technician to inspect the fireplace and to replace any parts of the control system and any gas controls which have been under water.



WARNING: ELECTRICAL GROUNDING

All electrical connections must be properly installed, insulated, and secured to avoid potential **ELECTRICAL SHOCK** and **FIRE HAZARD** and malfunction of the system. Consult local building code requirements. In the absence of local codes, refer to the National Electric Code, ANSI/NFPA 70, or the Canadian Electric Code, CSA C22.1.



WARNING: MATERIAL USAGE

All materials and objects used to carry out the installation must be certified/approved or specified by Ortal and are suitable for use. Do NOT install the system with different materials or objects than those approved for installation by Ortal.



WARNING: INSTALLATION AND SERVICE

Installation and repairs on the fireplace and vent system must be done by an authorized Ortal qualified installer service agency or gas supplier. If these components are not installed by an authorized Ortal dealer/installer, the warranty of all components will be void and Ortal will not be responsible for any damage caused by improper installation. The fireplace should be inspected before use and at least annually by a professional service person. More frequent cleaning may be required due to excessive lint from carpeting, bedding material, etc. Control compartments, burners and circulating air passageways of the fireplace must be kept clean. Any alteration to the product can cause soot or carbon to form and may result in damage. This damage and any other damage that results from not following the instructions outlined in this manual is not the responsibility of Ortal.



WARNING: HEAT BARRIER

A barrier designed to reduce the risk of burns from hot viewing glass is provided with this fireplace and shall be installed. The fireplace **MUST** not be used without the heat barrier in place. If the barrier becomes damaged, the barrier shall be replaced with the manufacturer's barrier for this fireplace. **Any safety screen, guard, or barrier removed for servicing the fireplace must be replaced before operating.**



WARNING: FIREPLACE TEMPERATURE

Due to hot temperatures, the fireplace should be located out of traffic and away from furniture and draperies.

Children and adults should be alerted to the hazards of high surface temperature and should stay away to avoid burns or clothing ignition. Clothing or other flammable material should not be placed on or near the fireplace. **Young children should be carefully supervised when they are in the same room as the fireplace.** Toddlers, young children, and others may be susceptible to accidental contact burns. A physical barrier is recommended if there are at-risk individuals in the house. To restrict access to a fireplace or stove, install an adjustable safety gate to keep toddlers, young children, and other at-risk individuals out of the room and away from hot surfaces.



WARNING: GLASS HANDLING

Only an Ortal certified installer is authorized to remove the glass using an 8-inch glass-handling suction cup.



WARNING: INSTALLATION AND OPERATION

The fireplace and accompanying components must be installed as an OEM installation in manufactured homes (USA only) or an aftermarket permanently located, or a mobile home, where not prohibited by local codes. The fireplace must be installed in accordance with the Manufacturer's instructions and the Manufactured Home Construction and Safety Standard, Title 24 CFR, Part 3280, in the United States, or the Standard for Installation in Mobile Homes, CAN/CSA Z240 MH Series, in Canada. **Exceeding the restrictions imposed in these instructions may result in a fire or explosion, causing property damage, personal injury, or loss of life. Ortal will not be responsible for any damage caused by improper installation. Do not store or use gasoline or other flammable vapors and liquids near this fireplace.**



WARNING: GAS FIREPLACE

This fireplace is for use only with the type of gas indicated on the rating plate. These fireplaces are not convertible for use with other gases unless a certified kit is used, and the conversion is performed by an authorized and qualified technician. Applicable standards are Vented Gas Fireplace Heaters ANSI Z21.88 / CSA 2.33a and Gas-fired Fireplaces for Use at High Altitudes CAN/CGA 2.17-M91



WARNING: CALIFORNIA PROP 65

These products and the fuels used to operate these products (liquid propane or natural gas), and the products of combustibles of such fuels, can expose you to chemicals including benzene, carbon monoxide, and ceramic fibers, which are known to the state of California to cause cancer and/or reproductive harm. For more information, visit www.p65warnings.ca.gov.

Table of Contents

“→” Denotes new or changed information from most recent version manual.

General	2
Safety Information and Warnings	2
Table of Contents	3
Product Information	5
Certification	5
→ Models	5
→ Product Dimensions	7
Rating Labels	13
Installation	14
Prior to Installation	14
Locate the Fireplace	14
→ Fireplace Installation	14
First Trip to Site: Planning	14
Second Trip to Site: Installation	14
→ Wall-Mounting Instructions	15
→ Base-Mounting Instructions	23
Third Trip to Site: Startup	29
Working with Glass Panels	29
Post-Installation	30
Initial Burning Period	30
Final Inspection Procedure	30
Final Checks and User Instruction	30
→ Clearances	31
Wall-Mounted Fireplace Clearances	31
Base-Mounted Fireplace Clearances	32
Decorative Skirt Removal	33
Screen Installation/Removal	34
Screen Removal	34
Screen Installation	35
Venting	36
General Venting Requirements	36
Vent Configurations	36
Maximum Allowable Horizontal Runs	37
Vent Restrictors	38
→ Vent Clearances	39
Vent Termination	40
Chimney Shroud	43
Vent Installation	43
Vent Maintenance	43
Gas	44
Gas Pressures	44
Routing the Gas Line	44
Wall-Mounted Fireplace	44
Base-Mounted Fireplace	45
Gas Conversion	45
High Altitude Requirements	45
Gas and Electrical Components	46
Electrical	47
Electrical Requirements	47
Power Outage	47
Pairing the Remote and Receiver	47
Wiring Diagrams	48
Interior Design Media	51
Media Placement Guidelines	51

Operation	53
→ 10-Button Remote Control Handset	53
→ Puck Handset	54
Wall Switch	56
→ MyFire App	57
Fireplace Maintenance	58
General Maintenance	58

Product Information

Certification

The Stand Alone TS series fireplaces have been tested and approved by CSA Group for safety and efficiency for use with Natural Gas (NG) and Propane (LP) only, and **NOT** for use with solid fuels.

CSA Group is approved by the American National Standards Institute (ANSI) as an Accredited Standards Developer.

Certification Listing:

US: ANSI Z21.88 – 2019: Vented Gas Fireplace Heaters

Canada: CSA 2.33 – 2019: Vented Gas Fireplace Heaters



Products:

CLASS 2901 84: DOMESTIC HEATERS (GAS) Vented Fireplace: Certified to US Standard

CLASS 2901 04: DOMESTIC HEATERS (GAS) Vented Fireplace

The fireplaces are permitted for indoor use only. “Indoor” is defined as a conditioned space. The fireplaces are not approved for outdoor or partial outdoor installation. The fireplaces must be installed while maintaining required clearances. Installation is recommended in living spaces such as bedrooms, living rooms, great rooms, etc. The fireplaces are not approved for closet installation. The fireplace must be installed according to Ortal requirements in addition to any local codes that may apply, such as USA: ANSI Z223.1/NFPA 54, Canada: CSA B149.

! IMPORTANT:

- Consult the authority having jurisdiction to determine the need for a permit prior to starting the installation.
- It is the responsibility of the fireplace dealer and installer to ensure that this fireplace is installed and framed in compliance with these instructions and all applicable codes.
- Before starting, take careful note of **ALL** the **WARNINGS** in this manual.

→ Models

Series	Model	Burner	Certification Standard	Gas Types	Direct Venting	→ Installation Options
Stand Alone TS	Stand Alone 40 TS	30 Single	US: ANSI Z21.88-2019 Canada: CSA 2.33-2019	Natural Gas or Propane	Type: Passive Vent Vent Size: 4"x6" (co-axial)	Wall-Mounted only
	Stand Alone 75 TS	45 Single				Wall-Mounted or Decorative Base
	Stand Alone 110 TS	100 Single			Type: Passive Vent Vent Size: 5"x8" (co-axial)	Wall-Mounted or Decorative Base

! NOTES: Venting is not supplied by Ortal with the fireplace. The fireplace is certified to be used with, and can be obtained from, the vent manufacturers outlined in “General Venting Requirements” section.

General Product Features

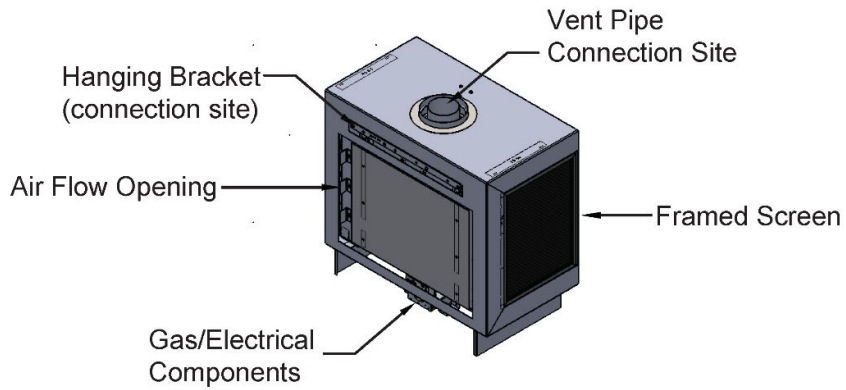
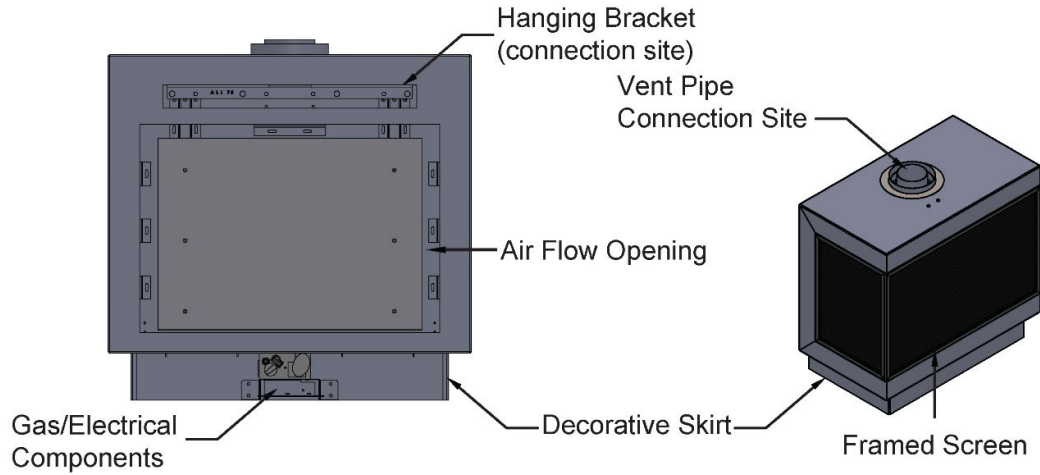

→ Decorative Base (optional add-on)

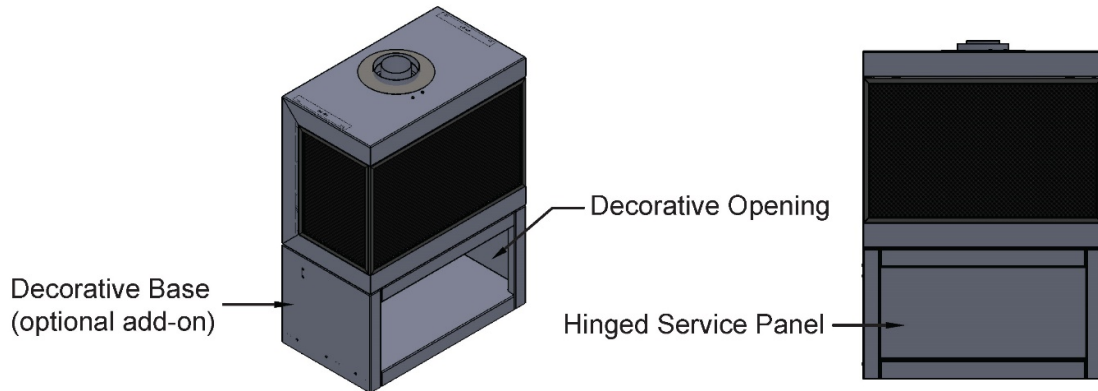

Back View
(Base only)

→ Product Dimensions

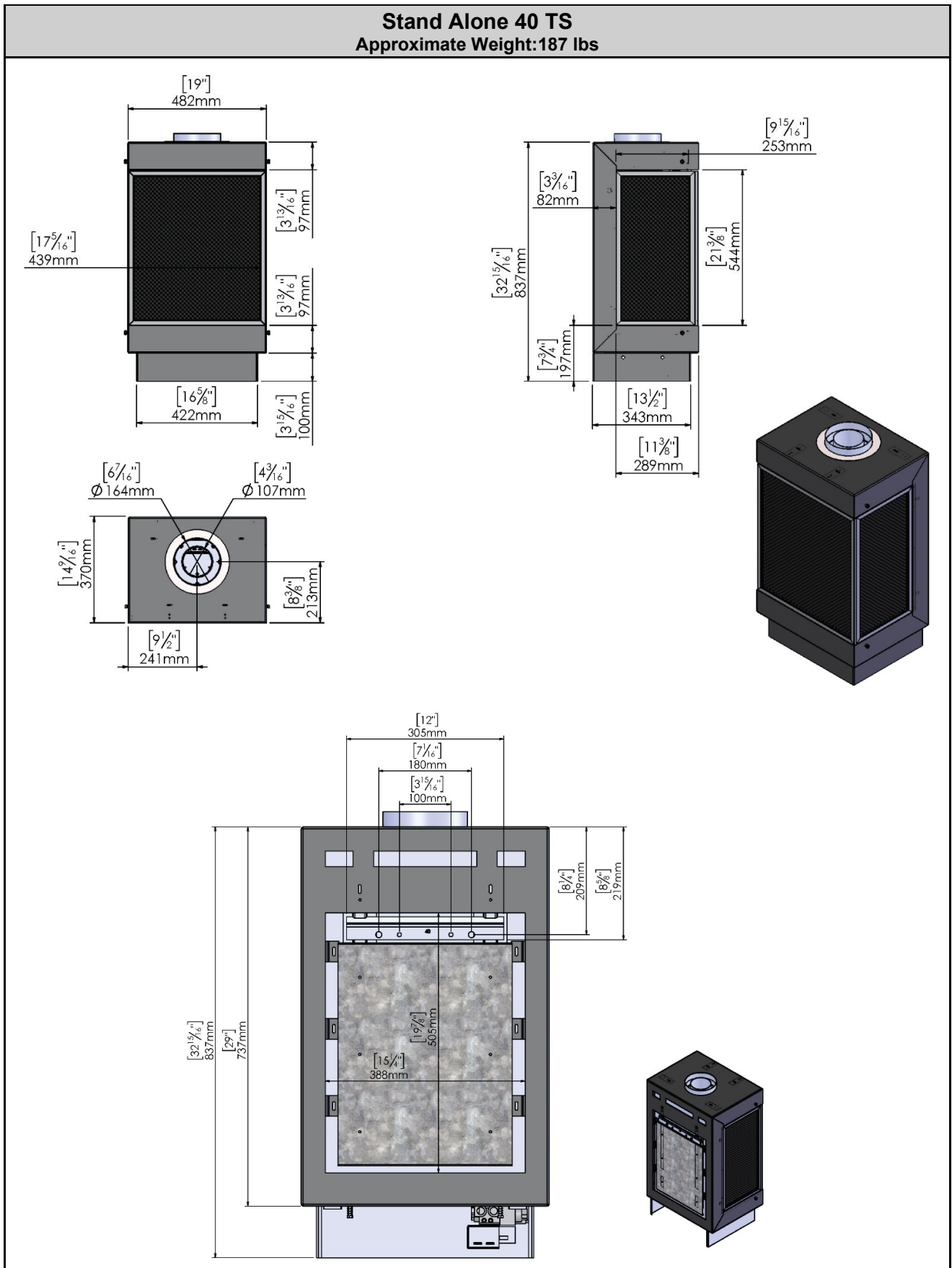

→ Hanging Bracket

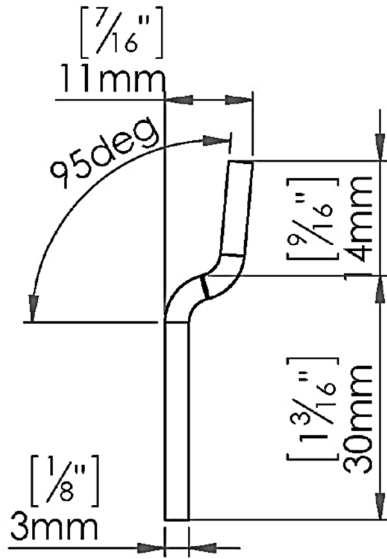

Side View

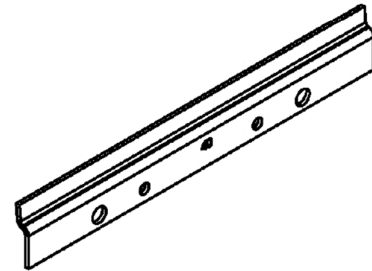
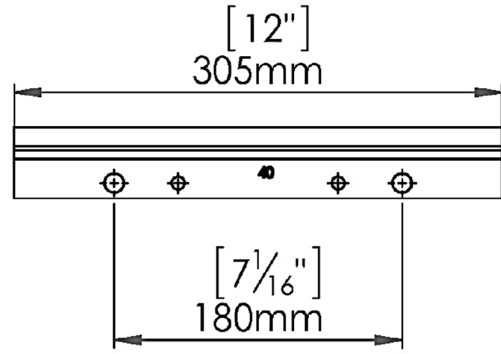

! NOTE: The Stand Alone 40 TS does not come with a decorative base option.

Stand Alone 75 TS
Approximate Weight: 254 lbs

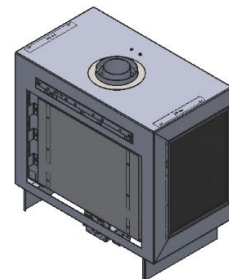
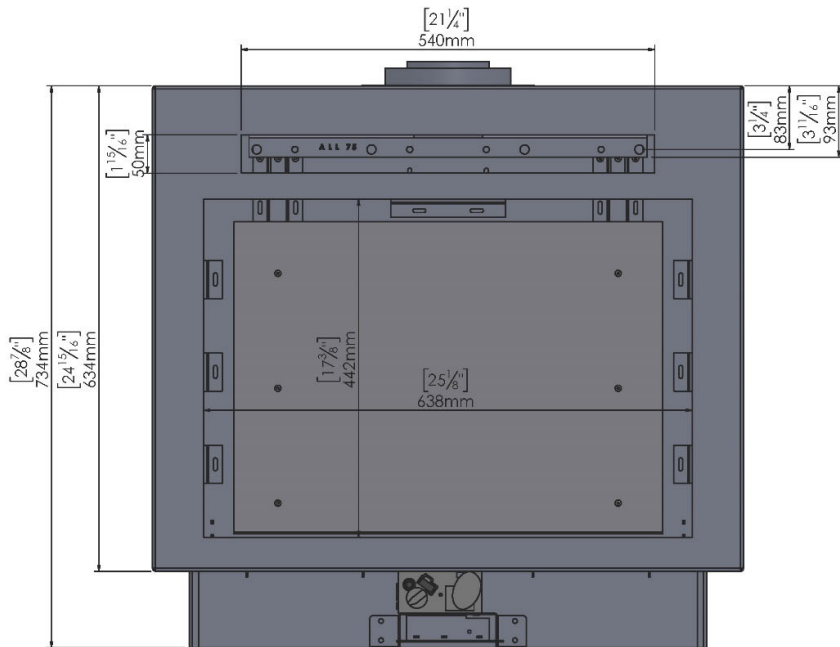
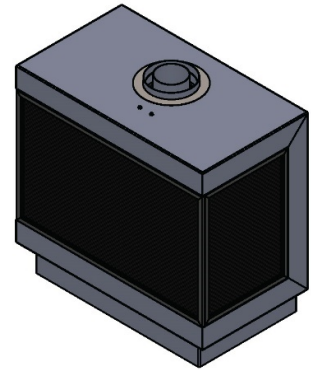
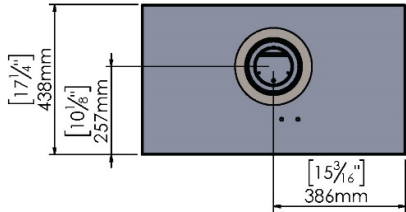
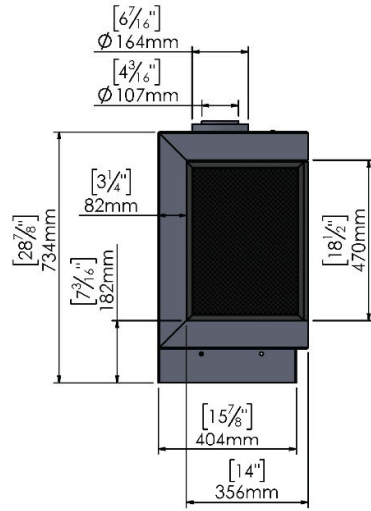
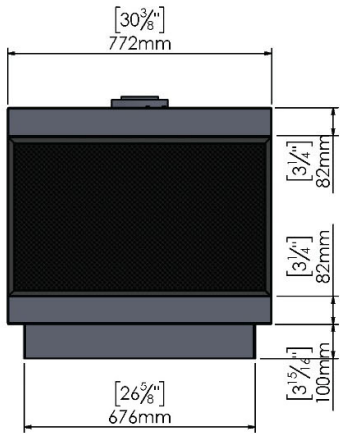

→ Hanging Bracket

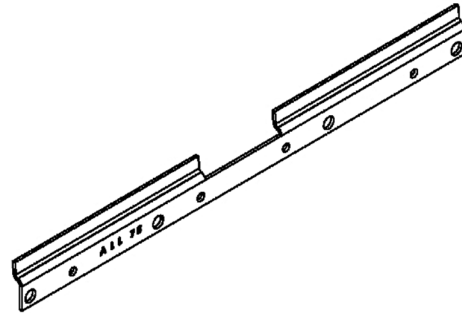
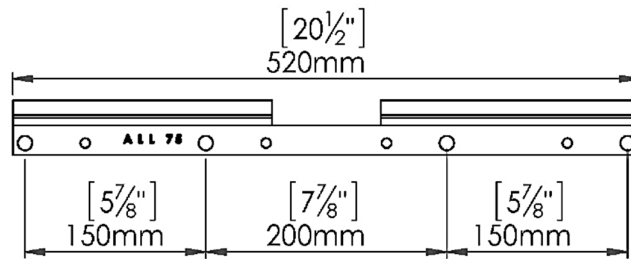
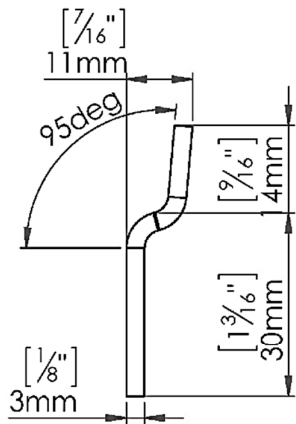

Stand Alone 75 TS with Decorative Base

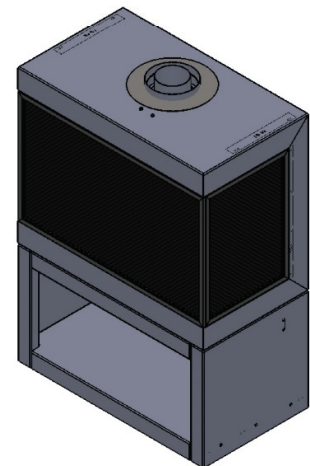
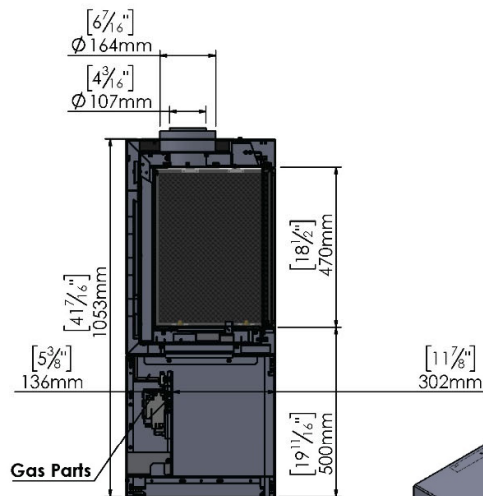
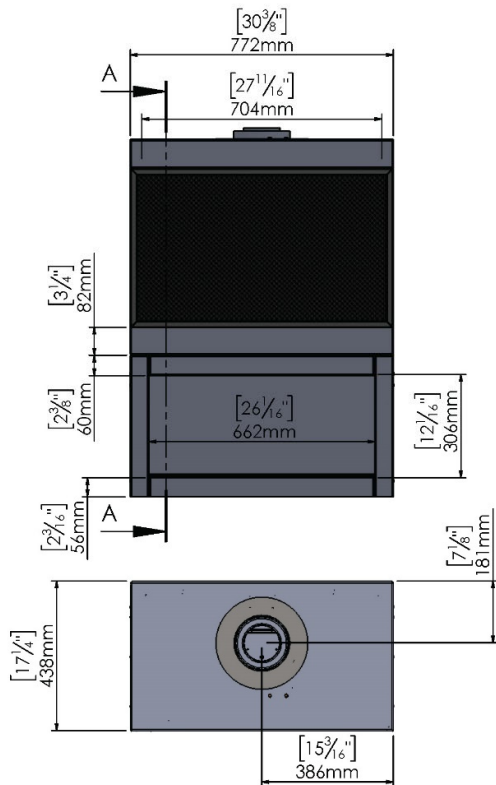

NOTE: The decorative base is an optional add-on feature manufactured by Ortal and is available for the Stand Alone 75TS and Stand Alone 110 TS. It allows the fireplace to be mounted to the base instead of a wall.

Stand Alone 110 TS
Approximate Weight: 331 lbs

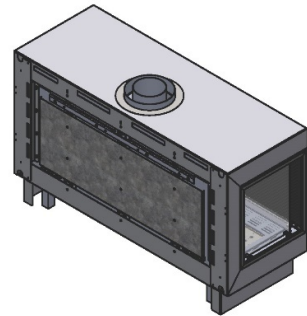
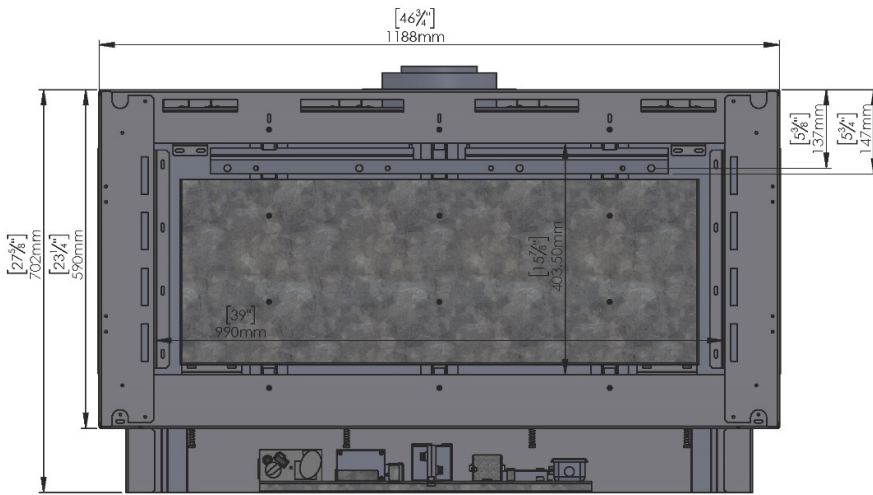
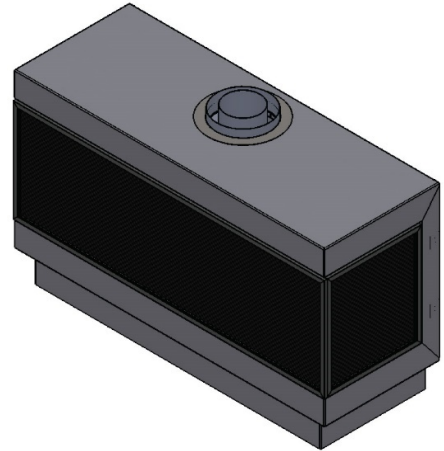
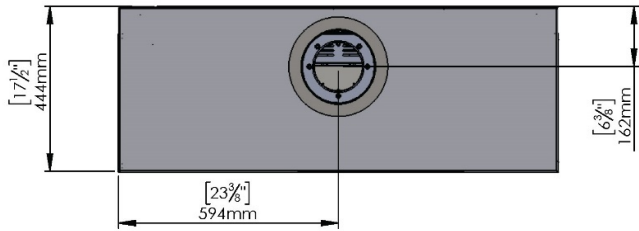
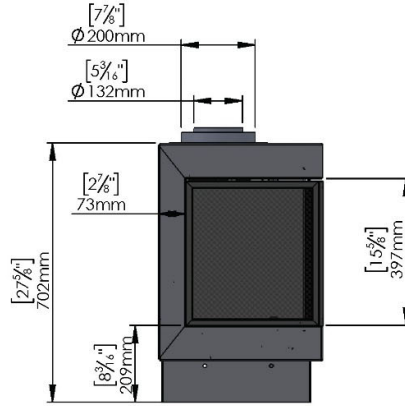
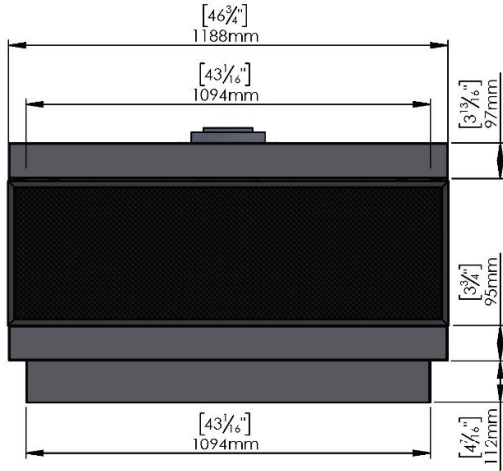

→ Hanging Bracket

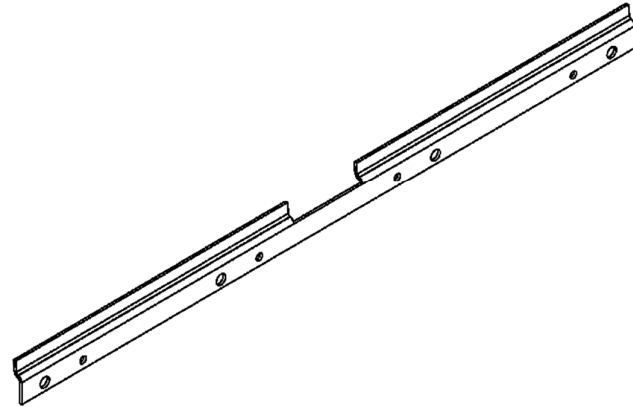
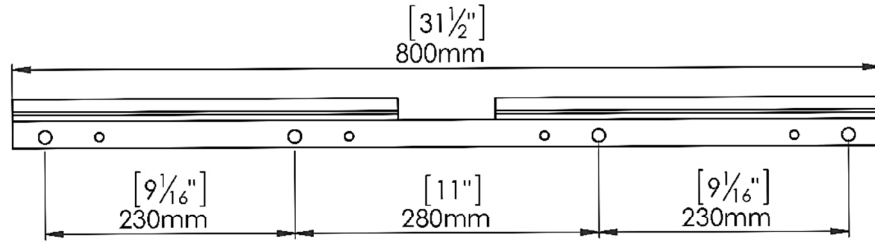
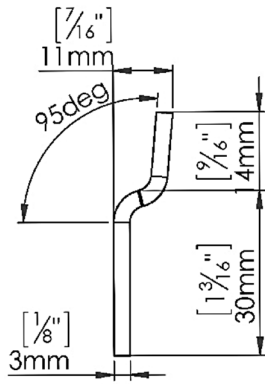

Stand Alone 110 TS with Decorative Base

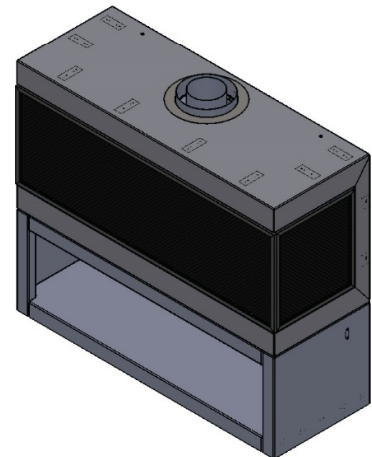
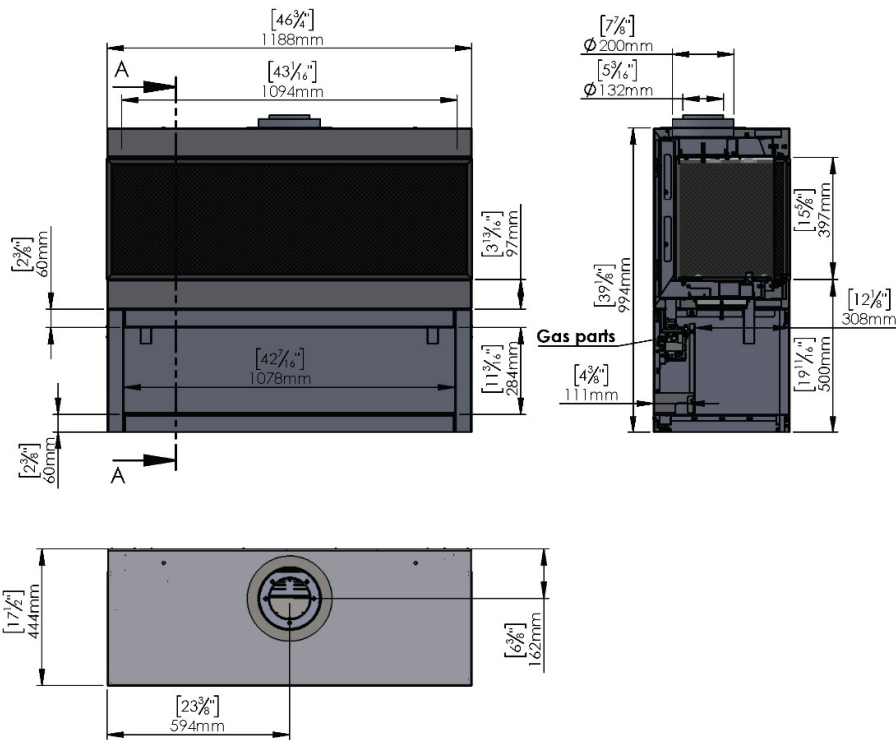

NOTE: The decorative base is an optional add-on feature manufactured by Ortal and is available for the Stand Alone 75TS and Stand Alone 110 TS. It allows the fireplace to be mounted to the base instead of a wall.

Rating Labels

The fireplace rating label is found on a metal plate separate included with the fireplace.

DEALERS/INSTALLERS:

You **MUST** leave the fireplace's rating label with the fireplace in an area easily accessible by the owner (typically near the access panel, if available). You must instruct the owner before handing over the fireplace where this label can be found.

OWNERS:

Make sure the installer leaves your fireplace's rating label in an area that is easily accessible for you. This information is required for servicing and receiving replacement parts.

Do Not Remove This Label
Ne pas retirer cette étiquette

For use only with vent, glass and interior design media certified and approved for use with the appliance. **Venté decorative gas appliance;**
Not a source of heat; Not for use with solid fuel. For use with barriers certified for this appliance only.
Utilisez uniquement avec des conduits, des panneaux vitrés et des accessoires décoratifs intérieurs homologués et approuvés pour une utilisation avec cet appareil. Appareil à gaz décoratif ventilé; pas une source de chaleur. Pas pour l'usage avec le combustible solide.
Pour une utilisation avec des barrières certifiées pour cet appareil uniquement.

Approved by / Homologué par :  no **2358468** Single Orifice Burner/Brûleur d'orifice singulier

Check one (check space to the right of the model name) / Cochez un choix (cochez à droite du nom du modèle) :

Clear 40 / RS / LS / TS / Tunnel Small Square
Stand Alone 40 TS Classic corner
Clear 4070 H / RS / LS / TS / Tunnel Modern corner
Clear 4090 H / RS / LS / TS / Tunnel Modern Classic

Serial No. / N° de série: _____

Manufacturer / Fabricant : ORTAL Heating Systems Ltd.
Inc. Zone B Neve Neeman, Hod Hasharon ISRAEL
Tel: 011 972 9 7402828
Fax: 011 972 9 7402687

Tested To / Examiné À: ANSI Z21.88/ CSA 2.33-2014
Electrical rating / Estimation Électrique: 110 volt / 60 Hz / less than 5A
Altitude rating / Estimation d'altitude: 0-2000 ft. / 0-610 m.

	S	S
Fuel Type / Type de combustible:	NL	PROPANE
Max Input / Débit max. (BTU/HR):	23,670	21,073
Min Input / Débit min. (BTU/HR):	10,419	12,841
Orifice Size / Taille de l'orifice:	650	220
Gas Inlet Pressure (W.C.) inches / Pression d'entrée de gaz (CE) pouces:	7.0	11.0
Gas manifold Pressure (W.C.) inches / Pression d'alimentation (CE) pouces:	3.2	10.9

Clearances to Combustibles / Espacement par rapport aux matériaux inflammables:
Sides / Côtés: 2" Back / Arrière: 2" In front of Glass / Devant le panneau vitré: 40"

Also adhere to clearance diagrams and instructions included in the ORTAL manual.
Adhérer également aux schémas d'espacement et des instructions figurant dans le manuel ORTAL.

Rating Label for Stand Alone 40 TS

ORTAL

Manufacturer / Fabricant: Ortal Ltd.
14 Haharash St. Hod Hasharon, 4524087 Israel
Tel: 011-972-9-7402828
Fax: 011-972-9-7402687

For use only with vent, glass and interior design media certified and approved for use with the appliance. Not for use with solid fuel. For use with barriers certified for this appliance only.
Utilisez uniquement avec des conduits, des panneaux vitrés et des accessoires décoratifs intérieurs homologués et approuvés pour une utilisation avec cet appareil. Pas pour l'usage avec le combustible solide. Pour une utilisation avec des barrières certifiées pour cet appareil uniquement.

Approved By: CSA No.: 2358468
Homologué Par:

Serial No.: _____

Tested to: CSA/ANSI Z21.88-2016 • CSA 2.33-2016 for Vented Gas Fireplace Heater
Examiné à: CSA/ANSI Z21.88-2016 • CSA 2.33-2016 pour Poêles-foyers ventilés

Altitude rating / Estimation d'altitude:	0-2000 ft. / 0-610 m.	Electrical Rating / Estimation Électrique:	110 volt / 60 Hz / less than 5A
--	-----------------------	--	---------------------------------

Model Series / Modèle Séries: 60x80/70/75/75x65 With 45 Burner

Clear 60x80 / Tunnel Standalone 75 / TS Classic F 75/80
 Clear 75 / RS/LS/TS/Base Standalone 75x65 / Tunnel Island 75
 Space Creator 75 Clear 75x65H / Tunnel Clear 7565 / TS
 Clear 75H RS/LS/TS Stand Alone 75x65 Curve/Tunnel Standalone 70 / TS

Fuel Type / Type de combustible:	NG/GN		PROPANE	
	Single Orifice	Double Orifice	Single Orifice	Double Orifice
Max Input / Débit max. (BTU/HR):	29,100	33,029	28,343	28,500
Min Input / Débit min. (BTU/HR):	16,147	18,327	15,627	17,796
Orifice Size / Taille de l'orifice:	650	380R*380F	320	160R*160F
Gas Inlet Pressure (W.C.) inches: / Pression d'entrée de gaz (CE) pouces:	7.0	7.0	11.0	11.0
Gas manifold Pressure (W.C.) inches: / Pression d'alimentation (CE) pouces:	4.7	4.7	9.5	10.7

Clearances to Combustibles / Espacement par rapport aux matériaux inflammables: Sides / Côtés: 2" Back / Arrière: 2" In front of Glass / Devant le panneau vitré: 40"

Also adhere to clearance diagrams and instructions included in the ORTAL manual.
Adhérer également aux schémas d'espacement et des instructions figurant dans le manuel ORTAL.

SKU: M209-B45DS

Rating Label for Stand Alone 75 TS

ORTAL

Manufacturer / Fabricant: Ortal Ltd.
14 Haharash St. Hod Hasharon, 4524087 Israel
Tel: 011-972-9-7402828
Fax: 011-972-9-7402687

For use only with vent, glass and interior design media certified and approved for use with the appliance. Not for use with solid fuel. For use with barriers certified for this appliance only.
Utilisez uniquement avec des conduits, des panneaux vitrés et des accessoires décoratifs intérieurs homologués et approuvés pour une utilisation avec cet appareil. Pas pour l'usage avec le combustible solide. Pour une utilisation avec des barrières certifiées pour cet appareil uniquement.

Approved By: CSA No.: 2358468
Homologué Par:

Serial No.: _____

Tested to: CSA/ANSI Z21.88-2019 • CSA 2.33-2019 for Vented Gas Fireplace Heater
Examiné à: CSA/ANSI Z21.88-2019 • CSA 2.33-2019 pour Poêles-foyers ventilés

Altitude rating / Estimation d'altitude:	0-2000 ft. / 0-610 m.	Electrical Rating / Estimation Électrique:	110 volt / 60 Hz / less than 5A
--	-----------------------	--	---------------------------------

Model Series / Modèle Séries: 110-130 With 100 Burner

Clear 110/RS/LS/TS/Tunnel Clear 130/RS/LS/TS/Tunnel Clear - 110 Base
 Clear 110H RS/LS/TS/Tunnel Clear 130H RS/LS/TS/Tunnel Clear - 110TS Base
 Clear 110HH RS/LS/TS/Tunnel Clear 130HH RS/LS/TS/Tunnel Island 130
 Stand Alone 110 / TS Space Creator 120 / Mini / Midi Space Creator 120H

Fuel Type / Type de combustible:	NG/GN		PROPANE	
	Single Orifice	Double Orifice	Single Orifice	Double Orifice
Max Input / Débit max. (BTU/HR):	37,167	42,185	35,316	42,185
Min Input / Débit min. (BTU/HR):	22,798	28,878	25,113	28,878
Orifice Size / Taille de l'orifice:	1200	650F*650R	380	180R*180F
Gas Inlet Pressure (W.C.) inches: / Pression d'entrée de gaz (CE) pouces:	7.0	7.0	11.0	7.0
Gas manifold Pressure (W.C.) inches: / Pression d'alimentation (CE) pouces:	8.6	5.0	10.0	5.0

Clearances to Combustibles / Espacement par rapport aux matériaux inflammables: Sides / Côtés: 2" Back / Arrière: 2" In front of Glass / Devant le panneau vitré: 40"

Also adhere to clearance diagrams and instructions included in the ORTAL manual.
Adhérer également aux schémas d'espacement et des instructions figurant dans le manuel ORTAL.

SKU: M209-B100DS

Rating Label for Stand Alone 110 TS

Installation

Prior to Installation

Locate the Fireplace

Keep the following factors in mind when selecting a location for the fireplace:

- Fireplace clearance requirements (review “Clearances” section on page 31).
- Fireplace mounting requirements (wall-mounted vs base-mounted). Review “Wall-Mounting Instructions” on page 15 or “Base-Mounting Instructions” on page 23.
- Adequate space for servicing.
- Minimum vertical vent rise, allowed horizontal lengths, and number and orientation of elbows (review “Venting” section on page 36).

→ Fireplace Installation

Use the following guidelines to ensure a smooth installation. The installation sequence is divided into three phases: Planning, Installation, and Startup.

First Trip to Site: Planning

Consult with the contractor and go over all requirements:

- Clearances around the fireplace.
- Gas and electrical specs and location.
- Vent configuration.

Second Trip to Site: Installation

- Clear a path free of any possible obstruction to carry in the fireplace.
- Uncrate the fireplace.
- Mount the fireplace at the desired location:
 - On a wall (see “Wall-Mounting Instructions” section on page 15 for details).
 - On the Ortol decorative base (see “Base-Mounting Instructions” section on page 23 for details).
- If fireplace is wall-mounted, remove shipping legs after installation.
- Install the vent components. See “Vent Installation” section on page 43
- Protect the fireplace and components from damage.

→ Wall-Mounting Instructions

The following sections explain how to mount the fireplace on either (1) wood-framed walls or (2) concrete/masonry walls. The diagrams in these sections are for illustration purposes only and apply to all models covered in this manual.

For clearances, see “Wall-Mounted Fireplace Clearances” section on page 31.

NOTE: Wall framing and mounting hardware (not provided) must be able to support the weight of the fireplace:

- Stand Alone 40 TS = 187 lbs.
- Stand Alone 75 TS = 254 lbs.
- Stand Alone 110 TS = 331 lbs.

Wood-Framed Wall

You will need to provide:

- 1/2" Cement Board (or equivalent)
- 3/8" diameter lag bolts (recommended bolt length is minimum 3" but may need to be longer depending on project design needs)
 - Stand Alone 40 TS requires 2 lag bolts
 - Stand Alone 75 TS & 110 TS requires 4 lag bolts

NOTE: For new construction projects, it is recommended to locate the non-combustible zone (step 1.3) before drywall is installed. For renovation projects, follow step 1 as written.

Step 1: Install Your Non-Combustible Zone

1. *Remove the Decorative Skirt:* Remove the decorative skirt from the bottom of the fireplace. (See “Decorative Skirt Removal” section on page 33 for instructions.) Keep the shipping legs on the fireplace until installation is complete.
2. *Position the Fireplace:* Using the fireplace and hanging bracket dimensions (see “Product Dimensions” section starting on page 7), determine the desired position of the fireplace on the wall, ensuring all required clearances are met (see “Wall-Mounted Fireplace Clearances” section on page 31 for details).
3. *Locate the Non-Combustible Zone:* Using the table and diagram below, locate the “Non-Combustible Zone” on your existing wall. No drywall or wood is permitted within this zone on the wall (this does not apply to the area behind the cement board, which will come up in a later step).

The table below lists the minimum non-combustible zone dimensions for each fireplace model. This zone will be larger than the size of the fireplace. The bottom of the fireplace (without the skirt) will line up with the bottom of this zone. **The zone will extend 12 inches above the top of the fireplace and 1/2 inch to each side.**

Minimum Non-Combustible Zone Dimensions:

Stand Alone 40 TS: 20" x 41"

Stand Alone 75 TS: 31 3/8" x 37"

Stand Alone 110 TS: 47 3/4" x 35 1/4"

(Dimensions = Width x Height)

NOTE: How to Calculate the Non-Combustible Zone

Width = Fireplace Width + (1/2" + 1/2")

Height = Fireplace Height (without skirt) + 12"

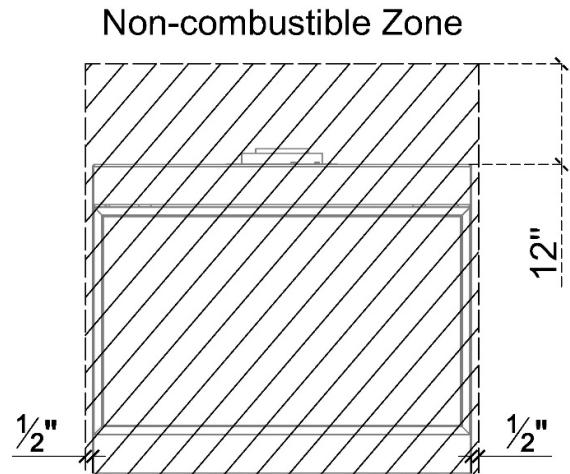

DIAGRAM NOTE: The fireplace is shown in the diagram above as a reference point only. The fireplace will not be mounted to the wall until step 5.

4. *Remove Existing Drywall:* For projects with existing drywall: Remove the existing drywall and finish within the non-combustible zone down to the wood stud framing, creating a cut-out in your wall. If your project is new construction without the drywall already installed, skip this step and move to #5.

5. *Locate the Hanging Bracket:* Using the dimensions in the table and diagram below, measure down from the center top your non-combustible zone. This is the center line for the bolts for the hanging bracket.

X Measurement:

Stand Alone 40 TS: X = 20 1/4"

Stand Alone 75 TS: X = 15 1/4"

Stand Alone 110 TS: X = 17 3/8"

Non-Combustible Zone

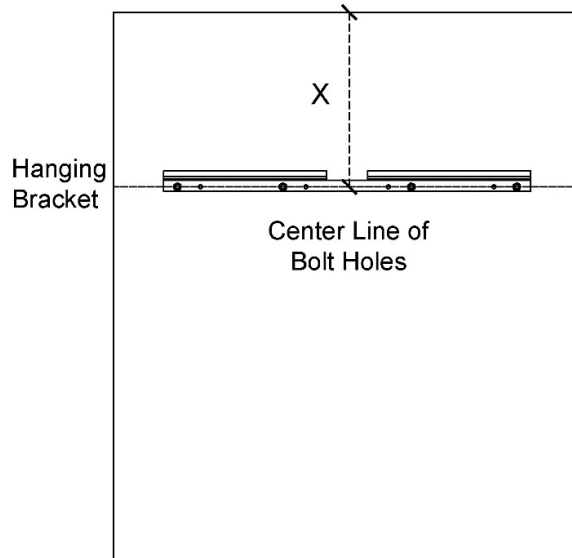

! DIAGRAM NOTE: The hanging bracket is shown in the diagram above as a reference point only. The hanging bracket will not be mounted to the wall until step 3.

6. *Insert Weight-Bearing Wood Blocks into the Wall:* At this location, secure enough 2"x6" wood blocks (or larger) between existing wood studs to span the width of the hanging bracket. The purpose of these wood blocks is to support the weight of the fireplace.

Hanging Bracket Width:

Stand Alone 40 TS: 12"

Stand Alone 75 TS: 20 1/2"

Stand Alone 110 TS: 31 1/2"

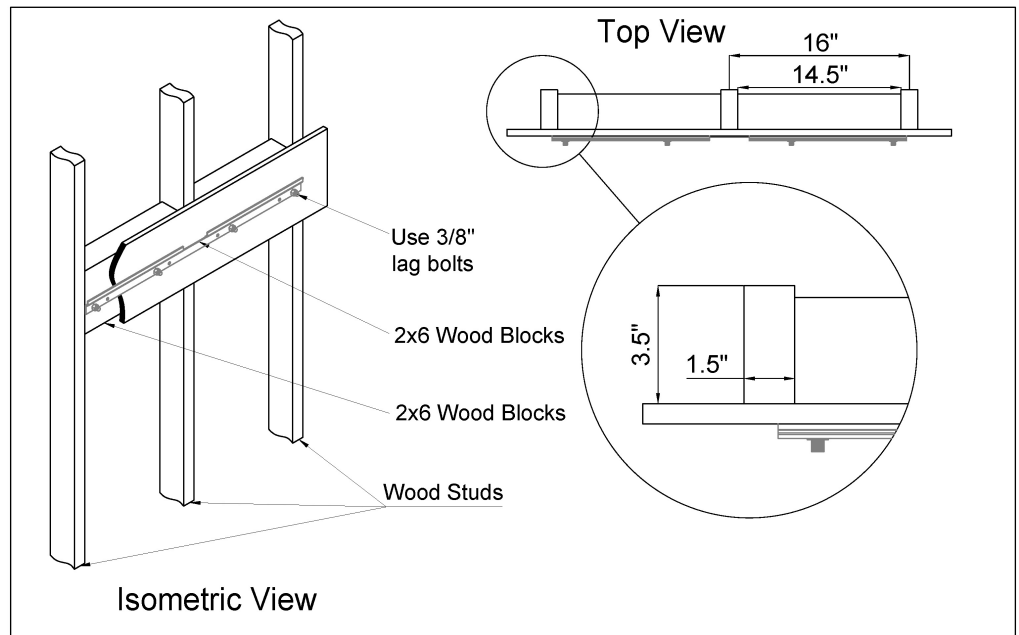

! DIAGRAM NOTE: The hanging bracket is shown in the diagram above as a reference point only. The hanging will not be mounted to the wall until step 3.

7. **Fill in Non-Combustible Zone:** Fill and secure the entire non-combustible zone with $\frac{1}{2}$ " cement board, fireplace construction board (e.g., Promat Promafour), or its equivalent, matching the thickness of the surrounding wall. This board will likely need to be oversized so it can be attached to framing studs. Dimension will vary per project.

Drywall (including $\frac{5}{8}$ " Type X Drywall) is not permitted within the non-combustible zone. Note: Drywall tape cannot go behind the fireplace, but it can go right up to the side or top of the fireplace (within the Non-Combustible Zone).

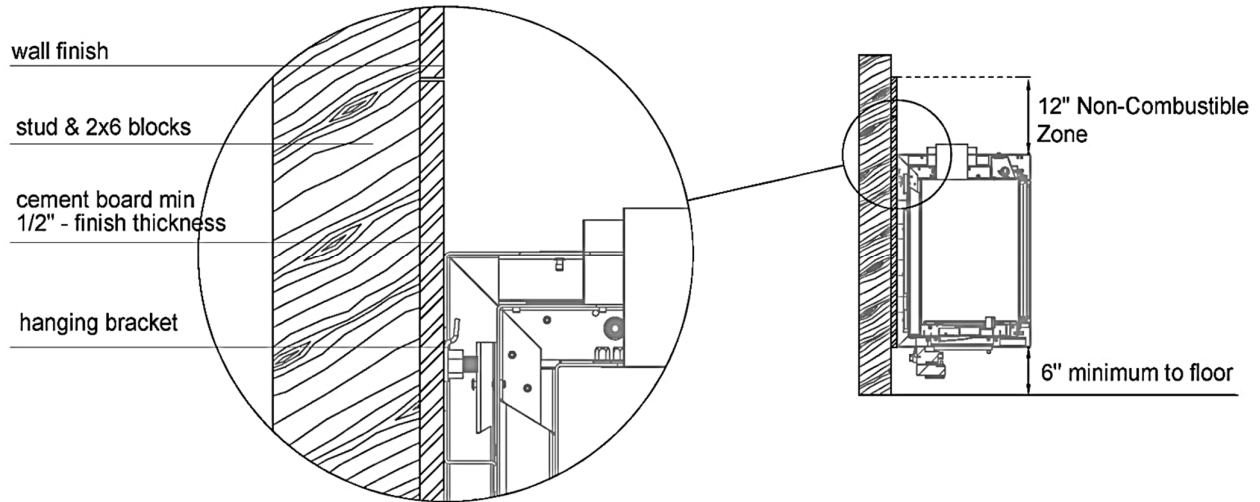

DIAGRAM NOTE: The fireplace is shown in the diagram above as a reference point only. The fireplace will not be mounted to the wall until step 5.

Step 2: Apply Wall Finish (optional)

1. **Apply Wall Finish Behind the Fireplace:** If it is desired to have the wall finish extend behind the fireplace (in the non-combustible zone), apply the wall finish now. Please note that combustible wall finishes with any thickness (such as wood) cannot enter the non-combustible zone. Wall finishes with no or negligible thickness (such as paint) that can withstand temperatures of up to 200°F can come within the non-combustible zone.

If no finish is desired behind the fireplace, skip this step.

Step 3: Mount the Hanging Bracket

1. **Locate the Hanging Bracket Location Again:** Using the dimensions in the table below, measure from the top of your non-combustible zone down and make a mark spanning the entire width of the fireplace. This line will mark the center of the bolt holes for the hanging bracket. This should line up with the center of the installed 2"x6" wood blocks in the wall. To ensure the fireplace will be level on the wall, it is recommended to use a leveling tool when making your mark for the bracket location.

X Measurement:

Stand Alone 40 TS: X = 20 $\frac{1}{4}$ "

Stand Alone 75 TS: X = 15 $\frac{1}{4}$ "

Stand Alone 110 TS: X = 17 $\frac{3}{8}$ "

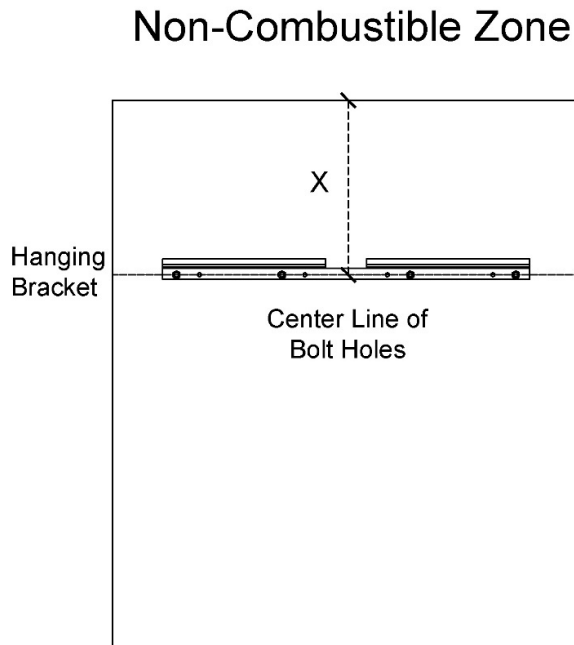

2. **Mount the Hanging Bracket:** Center the hanging bracket along the line marking you just made. Using the information in the table below, mount the bracket to the wall using the $\frac{3}{8}$ "-diameter lag bolts following the bolt manufacturer's requirements (bolts are not provided). Recommended bolt length is minimum 3" but may need to be longer depending on project design needs.

Qty Lag Bolts:

Stand Alone 40 TS requires 2 lag bolts

Stand Alone 75 TS requires 4 lag bolts

Stand Alone 110 TS requires 4 lag bolts

Use $\frac{3}{8}$ " diameter lag bolts
(not provided)

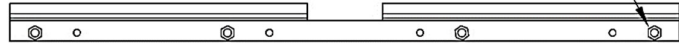

NOTE: To ensure the fireplace can be installed tightly to the wall, make sure the bolt doesn't stick out more than $\frac{5}{8}$ " from the wall.

Step 4: Mark the location of the fireplace gas line and electrical outlet.

1. **Find the Gas and Electrical Locations on the Wall:** Route the gas line to the bottom right of the fireplace and the outlet to the bottom left (in reference to a front view of the fireplace). Refer to the table below for measurements.

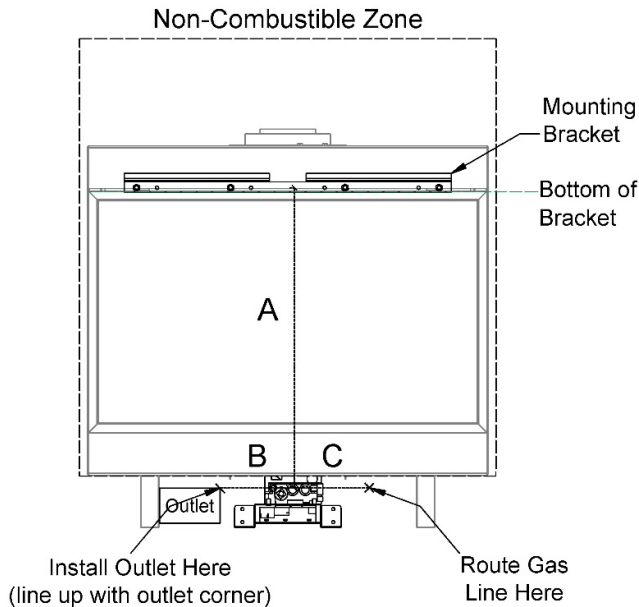

A = Distance from bottom of hanging bracket to center line of gas valve opening.

B = Distance from bottom of A to the start of the electrical outlet (not provided)

C = Distance from bottom of A to where gas line should be routed.

Front View

DIAGRAM NOTE: The fireplace is shown in the diagram above as a reference point only. The fireplace will not be mounted to the wall until step 5.8

Model	Dimensions		
	A	B	C
Stand Alone 40 TS	21 $\frac{3}{8}$ "	3"	5 $\frac{1}{2}$ "
Stand Alone 75 TS	22 $\frac{1}{4}$ "	6 $\frac{1}{4}$ "	8 $\frac{5}{8}$ "
Stand Alone 110 TS	18 $\frac{1}{2}$ "	12 $\frac{1}{4}$ "	14 $\frac{5}{8}$ "

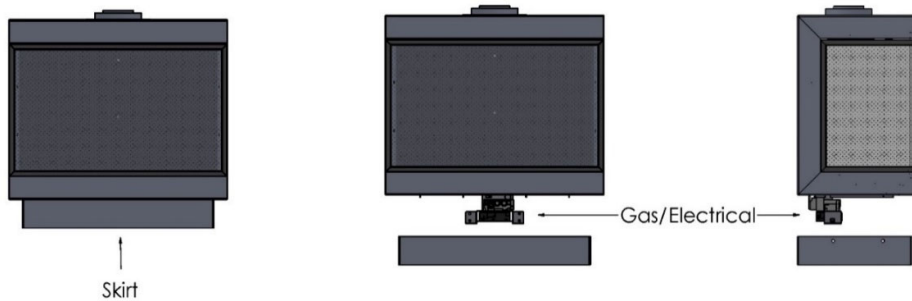

NOTE: The decorative skirt will hide the gas/electrical components once reinstalled.

Stand Alone 40 TS Skirt height: 3 $\frac{15}{16}$ "

Stand Alone 75 TS Skirt height: 3 $\frac{15}{16}$ "

Stand Alone 110 TS Skirt height: 4 $\frac{7}{16}$ "

Step 5: Mount the Fireplace to the Wall

1. *Recommended – Make a Vertical Mark on the Wall:* Find the center of the top of the hanging bracket and make a vertical mark at a 90° angle to the hanging bracket. This will be used as a guide to center the fireplace while attaching it to the hanging bracket. The mark will need to extend high enough to be seen while hanging the fireplace to the wall.
2. *Hang the Fireplace:* Attach the fireplace to the hanging bracket as shown in diagram below, ensuring the z-channels of the hanging bracket and fireplace are properly mated. After hanging, you can ensure proper engagement of the hanging bracket to the fireplace by checking that the top line marking on the wall lines up with the top of the fireplace.

Hanging Bracket
Connection
Opening

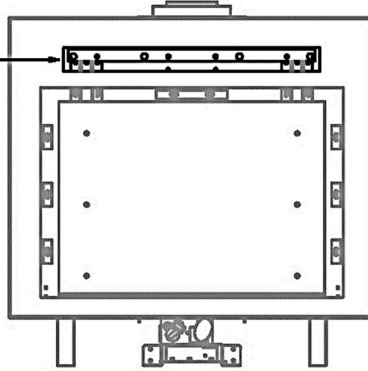

Back View

Hanging
Bracket

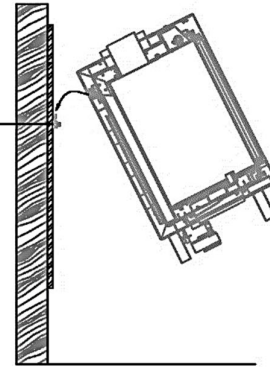

Side View

Fireplace-Bracket
Connection

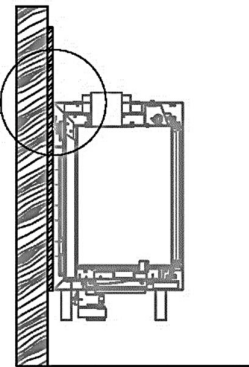
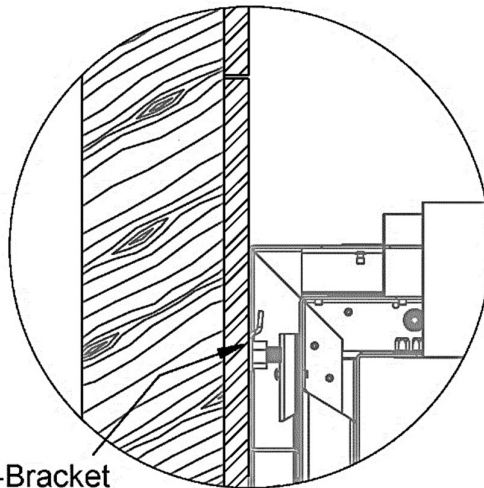

Side View

3. *Remove Legs:* Using a 10mm wrench (provided), unbolt and remove the shipping legs and reattach the decorative skirt to the bottom of the fireplace. See "Decorative Skirt Removal" section on page 33 for instructions.

Step 6: Apply Wall Finish (optional)

1. *Apply Wall Finish Around the Fireplace:* If the wall finish has not been installed yet, apply the wall finish now. Please note that combustible wall finishes with any thickness (such as wood) cannot enter the non-combustible zone. Wall finishes with no or negligible thickness (such as paint) that can withstand temperatures of up to 200°F can come within the non-combustible zone.

Concrete or Masonry Wall

You will need to provide:

- $\frac{3}{8}$ " diameter extension bolts (recommended bolt length is minimum 3" but may need to be longer depending on project design needs)
 - Stand Alone 40 TS requires 2 expansion bolts
 - Stand Alone 75 TS & 110 TS requires 4 expansion bolts

NOTE: This section assumes the non-combustible finish is already in place.

Step 1: Mark the desired location of the fireplace on the wall.

1. *Remove the Decorative Skirt:* Remove the decorative skirt from the bottom of the fireplace. See "Decorative Skirt Removal" section on page 33 for instructions. Keep the shipping legs on the fireplace until installation is complete.
2. *Mark the Desired Fireplace Location on the Wall:* Using the fireplace and hanging bracket dimensions (see "Product Dimensions" section starting on page 7), determine the desired location of the fireplace on the wall, and mark the location of the top, bottom, and sides of the fireplace, ensuring all required clearances are met (see section "Wall-Mounted Fireplace Clearances" on page 31).

DIAGRAM NOTE: The fireplace is shown in the diagram to the right as a reference point only. The fireplace will not be mounted to the wall until step 4.

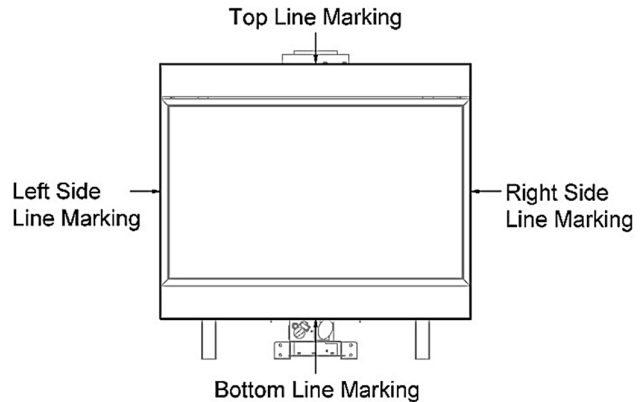

Step 2: Mount the hanging bracket.

1. *Mark Desired Hanging Bracket Location:* Using the dimensions in the diagram below, measure down from your top line marking (indicating the top of the fireplace) and make another mark spanning the entire width of the fireplace. This will be the center of the bolt holes for the hanging bracket. To ensure the fireplace will be level on the wall, it is recommended to use a leveling tool when making your marking for the bracket location.

X Measurement:

Stand Alone 40 TS: X = 8 $\frac{1}{4}$ "

Stand Alone 75 TS: X = 3 $\frac{1}{4}$ "

Stand Alone 110 TS: X = 5 $\frac{3}{8}$ "

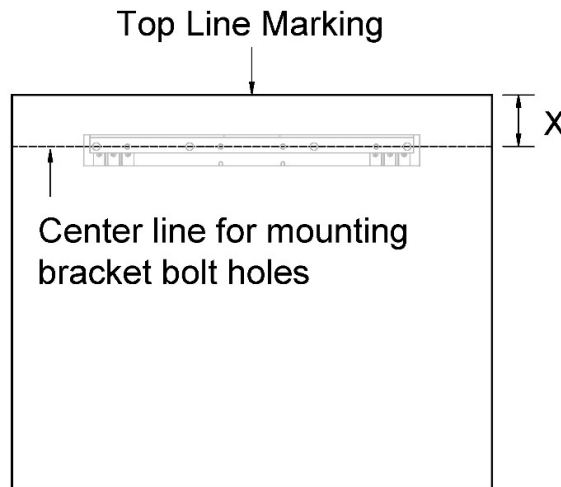

2. *Mount the Hanging Bracket:* Center the hanging bracket along the line marking made in Step 2.1. Using the information in the table below, mount the bracket to the wall using the $\frac{3}{8}$ "-diameter expansion bolts following the bolt manufacturer's requirements (bolts are not provided). Recommended bolt length is minimum 3" but may need to be longer depending on project design needs.

Qty Expansion Bolts:

Stand Alone 40 TS requires 2 expansion bolts

Stand Alone 75 TS requires 4 expansion bolts

Stand Alone 110 TS requires 4 expansion bolts

Use $\frac{3}{8}$ " diameter expansion bolts
(not provided)



NOTE: To ensure the fireplace can be installed tightly to the wall, make sure the bolt doesn't stick out more than $\frac{5}{8}$ " from the wall.

Step 3: Mark the location of the gas line and electrical outlet on the wall.

1. *Find the Gas and Electrical Locations on the Wall:* Route the gas line to the bottom right of the fireplace and the outlet to the bottom left (in reference to a front view of the fireplace) using the hanging bracket marking made in Step 2.1. Refer to the diagram below for measurements.

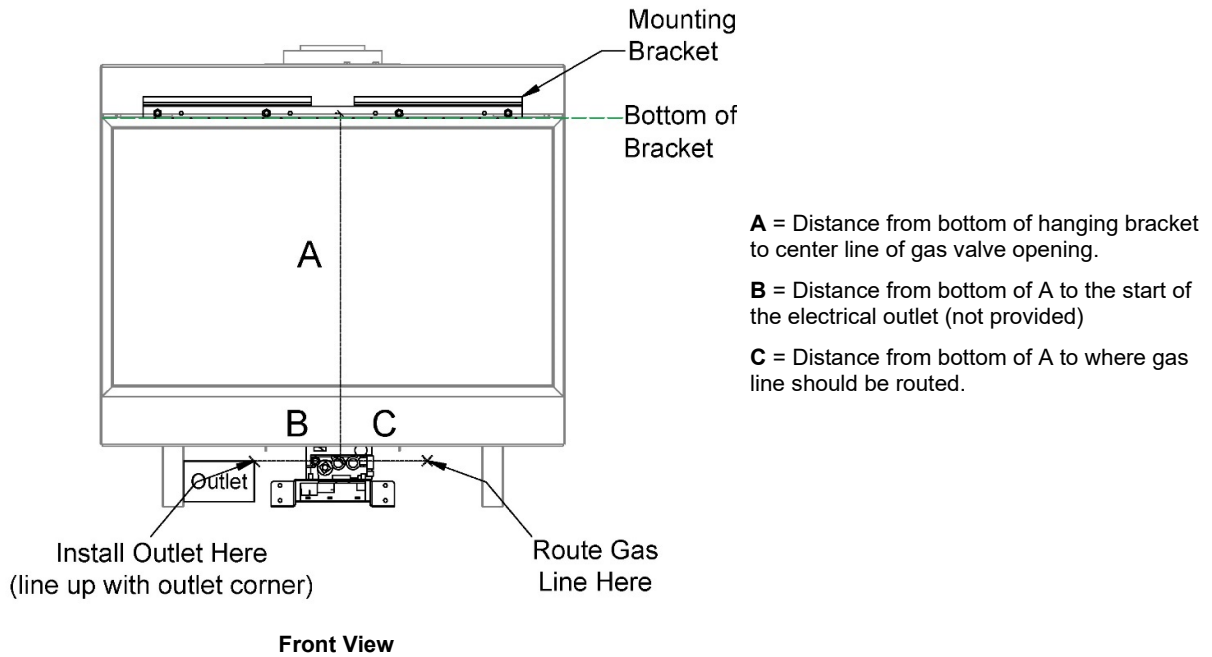

! DIAGRAM NOTE: The fireplace is shown in the diagram above as a reference point only. The fireplace will not be mounted to the wall until step 4.

Model	Dimensions		
	A	B	C
Stand Alone 40 TS	21 ³ / ₈ "	3"	5 ¹ / ₂ "
Stand Alone 75 TS	22 ¹ / ₄ "	6 ¹ / ₄ "	8 ⁵ / ₈ "
Stand Alone 110 TS	18 ¹ / ₂ "	12 ¹ / ₄ "	14 ⁵ / ₈ "

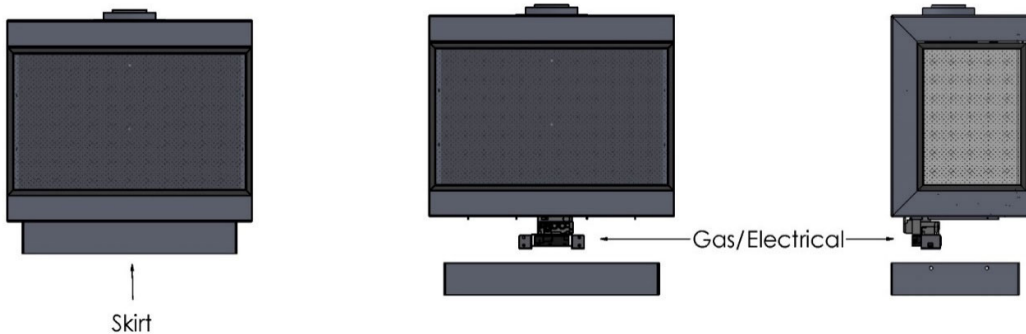

! NOTE: The decorative skirt will hide the gas/electrical components once reinstalled.

- Stand Alone 40 TS Skirt height: 3 ¹⁵/₁₆"
- Stand Alone 75 TS Skirt height: 3 ¹⁵/₁₆"
- Stand Alone 110 TS Skirt height: 4 ⁷/₁₆"

Step 4: Mount the Fireplace to the Wall

1. *Recommended – Make a Vertical Mark on the Wall:* Find the center of the hanging bracket and make a vertical mark at a 90° angle to the hanging bracket. This will be used as a guide to center the fireplace while attaching it to the hanging bracket. The mark will need to extend high enough to be seen while hanging the fireplace to the wall.
2. *Hang the Fireplace:* Attach the fireplace to the hanging bracket as shown in diagram below, ensuring the z-channels of the hanging bracket and fireplace are properly mated. After mounting, you can ensure proper engagement of the hanging bracket to the fireplace by checking that the top line marking on the wall lines up with the top of the fireplace.

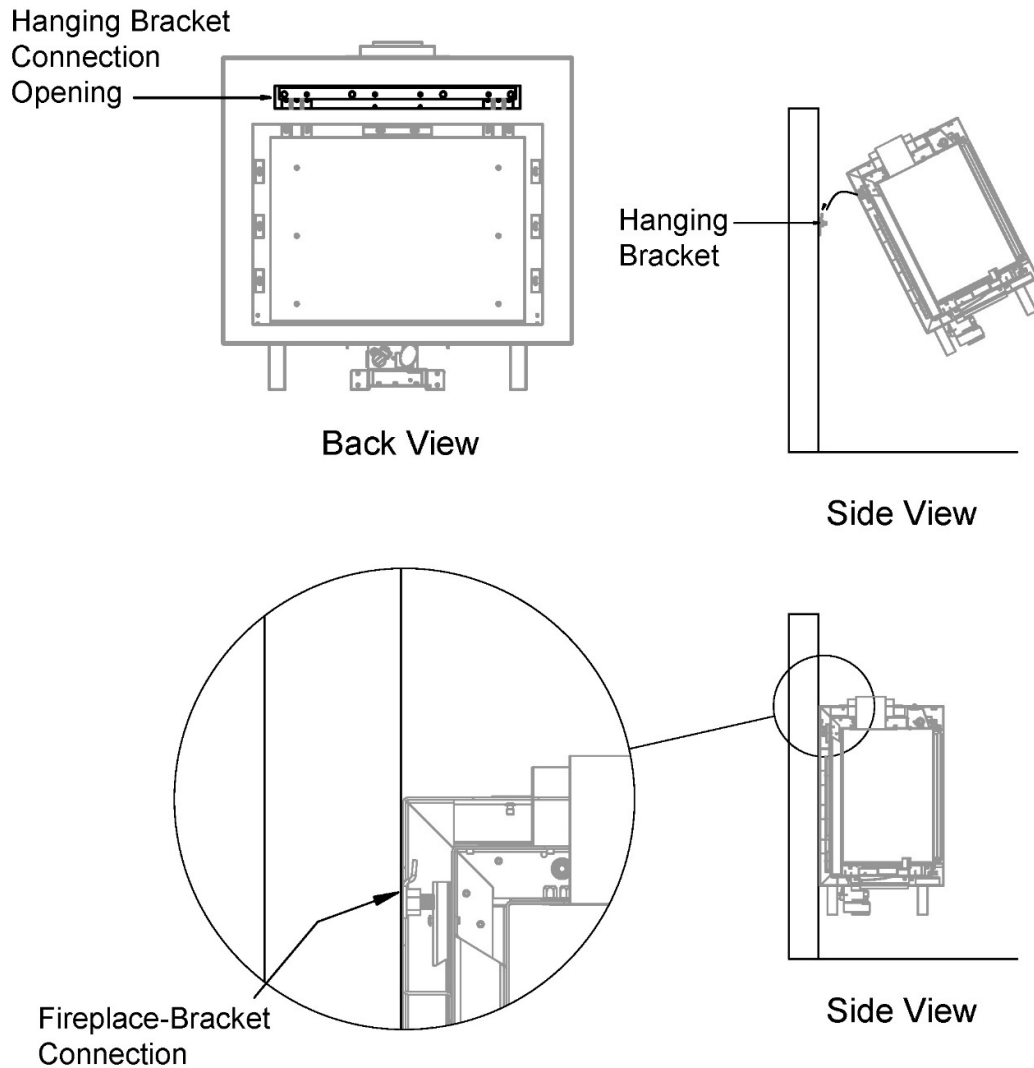

3. *Remove Legs:* Using a 10mm wrench (provided), unbolt and remove the shipping legs and reattach the decorative skirt to the bottom of the fireplace. See "Decorative Skirt Removal" section on page 33 for instructions.

→ **Base-Mounting Instructions**

This section explains how to attach the fireplace to the Ortal Decorative Base. The fireplace does not need to be mounted to a wall if it is attached to this base. The base fully supports the entire weight of the fireplace.

The diagrams in these sections are for illustration purposes only and apply to all models covered in this manual.

For clearances, see “Base-Mounted Fireplace Clearances” section on page 32.

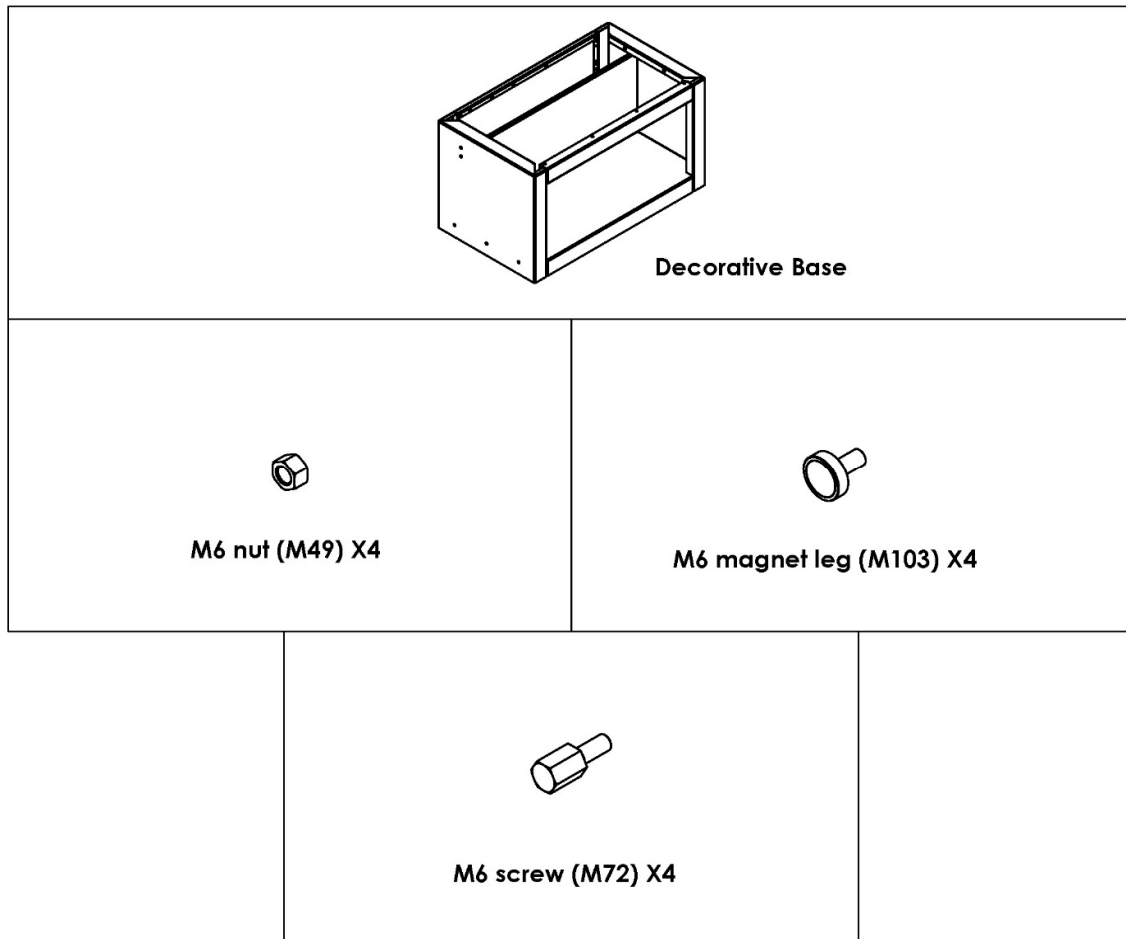

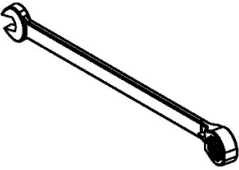
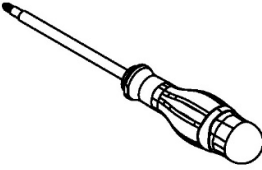
Tools Needed	
 Wrench (10mm) (supplied)	 Phillips head screwdriver (PH3) (not supplied)

! NOTE: 2 x 1/2" (13mm) diameter bolts used in step 3 are not supplied.

Step 1

Place decorative base in the desired location.

Step 2

Pull hinged service panel out and down as shown in figure (1) to reveal floor attachment sites.

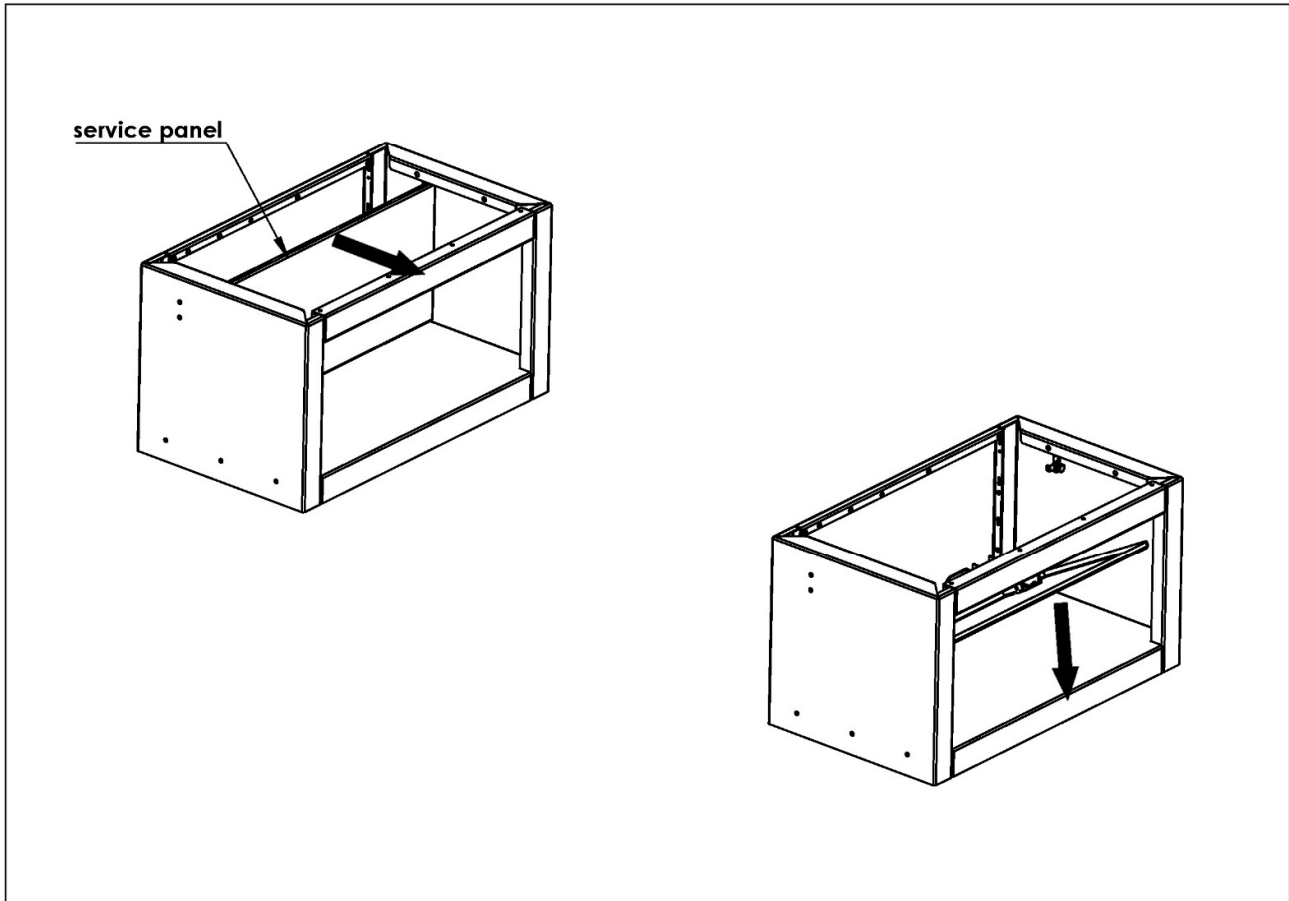

Figure (1)

Step 3:

Find two semi circle openings on the bottom of the base. Screw a 1/2"-diameter (13mm) bolt into each of the two holes. Sleeve anchors are recommended for attaching to concrete flooring.

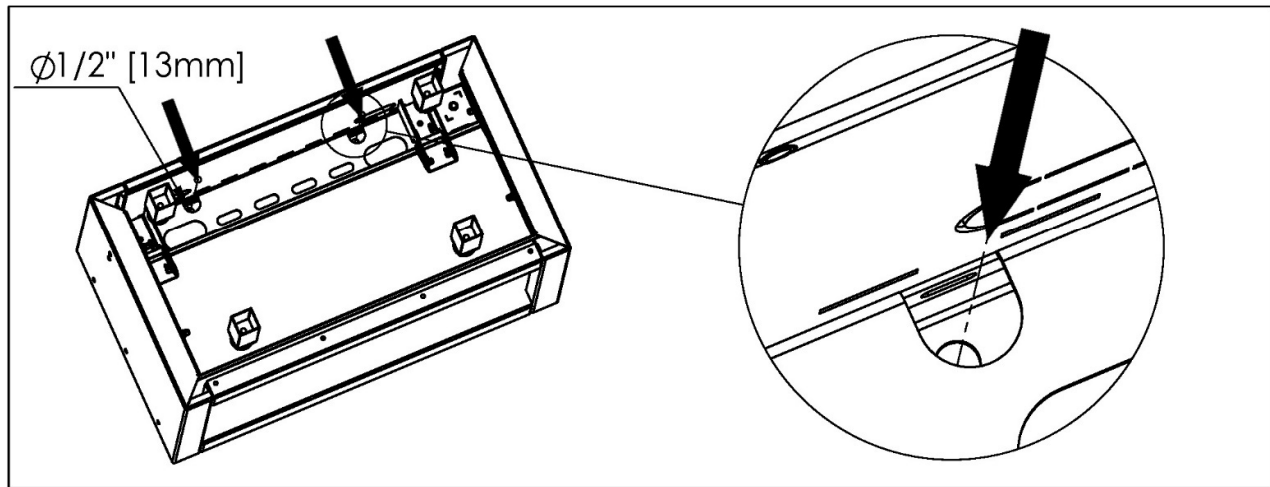

Figure (2)

Step 4

Using a Phillips head screwdriver (PH3), disconnect the decorative skirt at the bottom of the fireplace by removing the screws that are holding the skirt in place (2 per side, 4 total), as shown in figure (3) below.

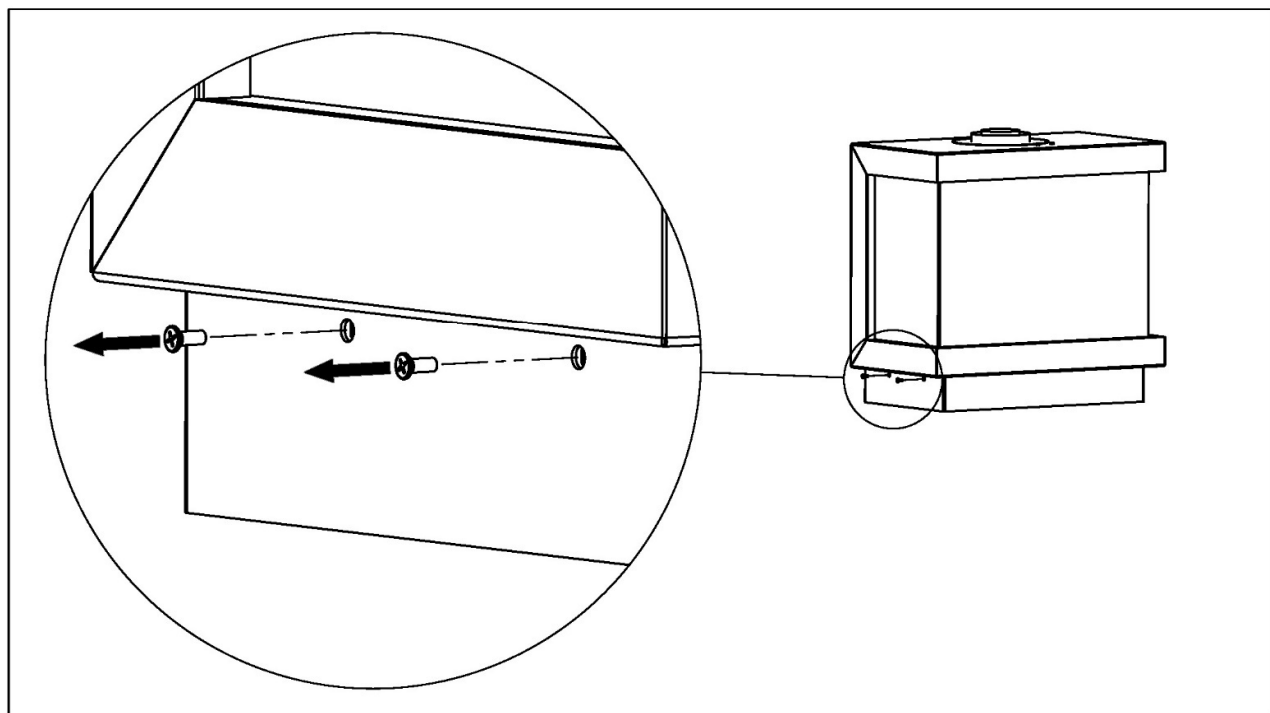

Figure (3)

Step 5

Pull skirt out towards you to remove, as shown in figure (4).

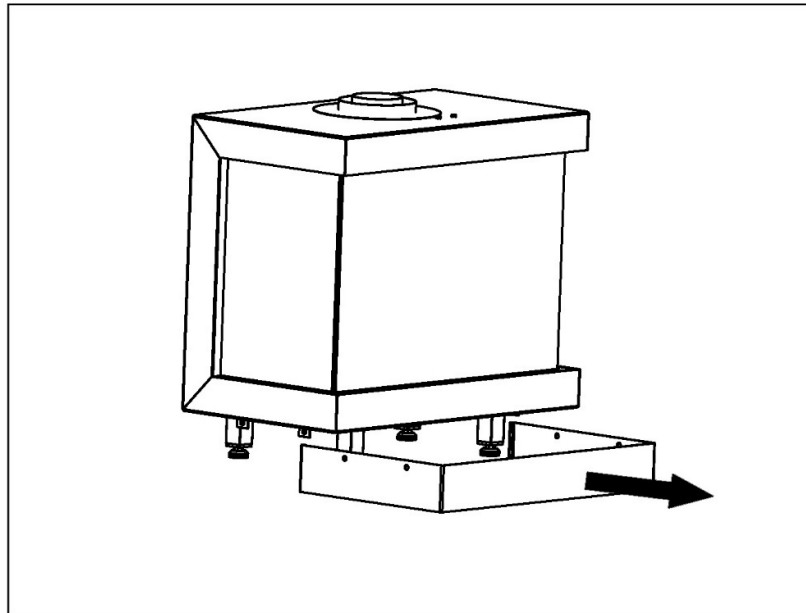

Figure (4)

Step 6

Carefully place the fireplace on top of the decorative base as shown in figure (5). A minimum of 2 people are required to lift the fireplace. The service plate should be placed behind the service panel.

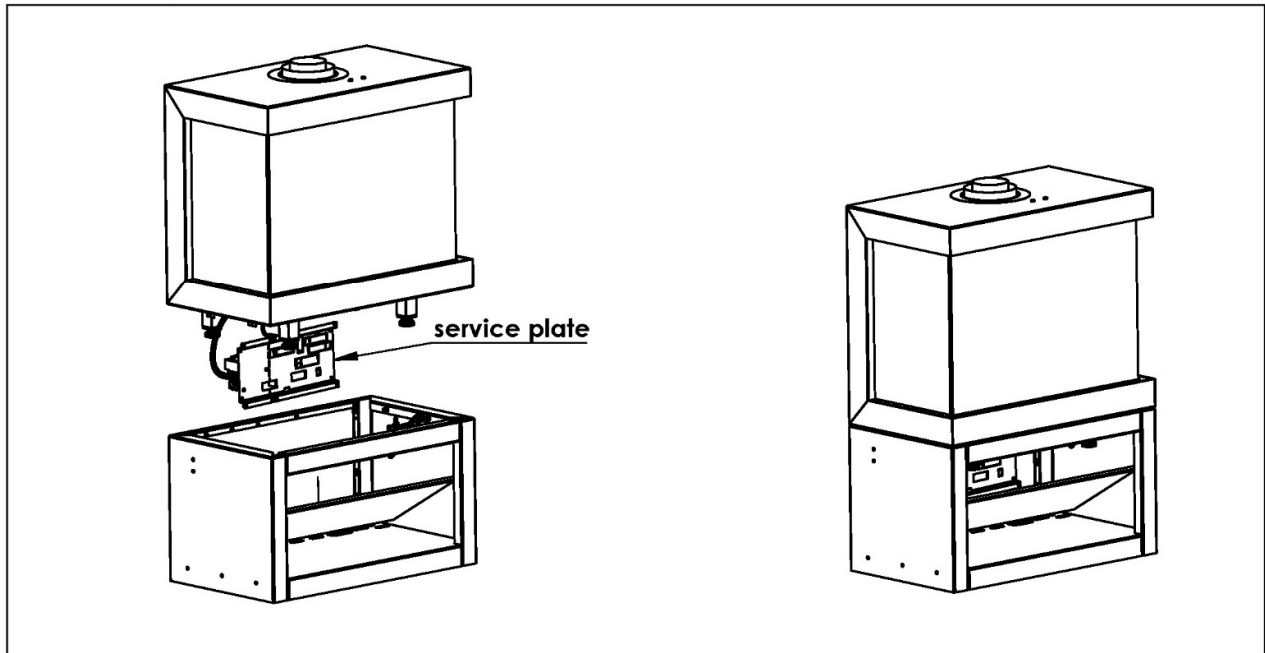

Figure (5)

Step 7

Attach the 4 supplied M6 Magnetic Screws to the service plate using the supplied M6 Nuts as shown in figure (6).

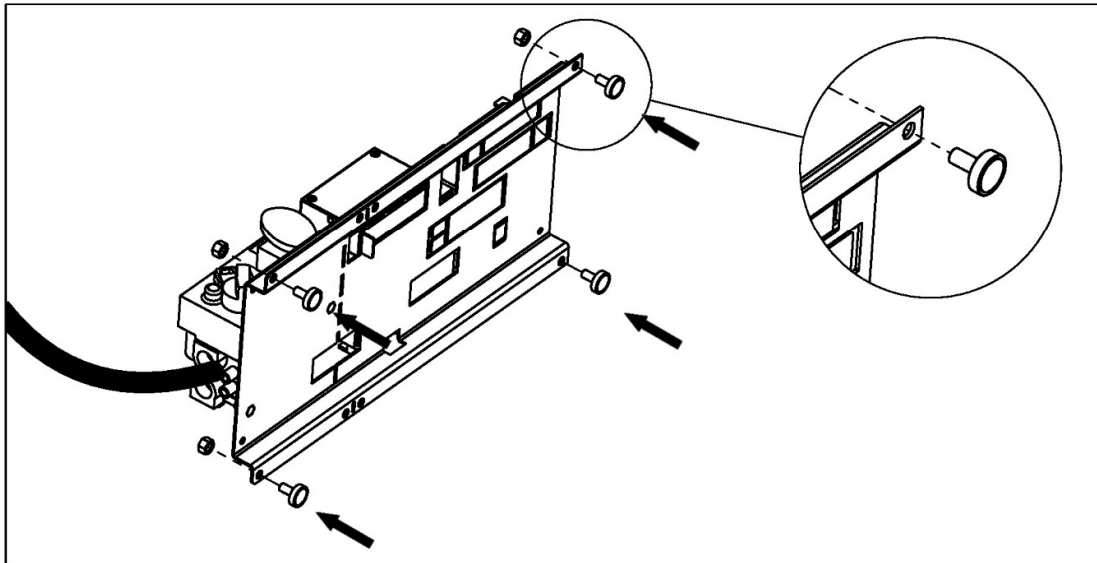

Figure (6)

Step 8

Fasten the magnetic side of the service plate to the inner side of the service panel. Orient service plate as shown in figure (7).

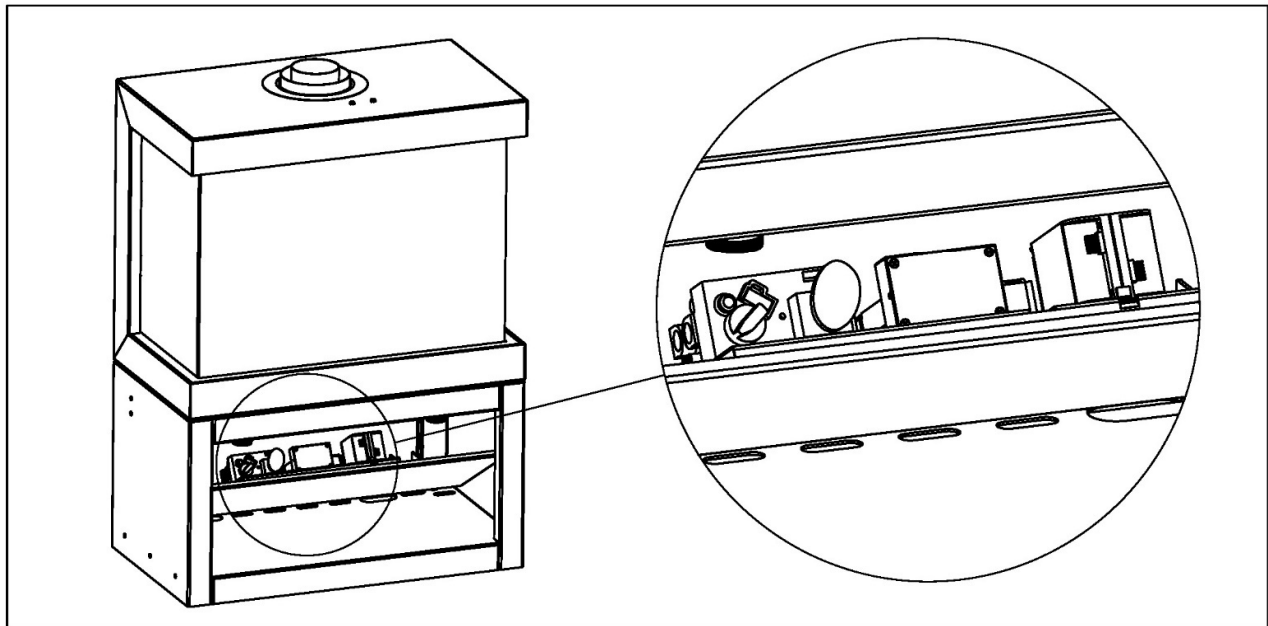

Figure (7)

Step 9

Secure the fireplace to the base using the supplied M6 Hex Head Screws (2 per side) and 10mm wrench, as shown in figure (8).

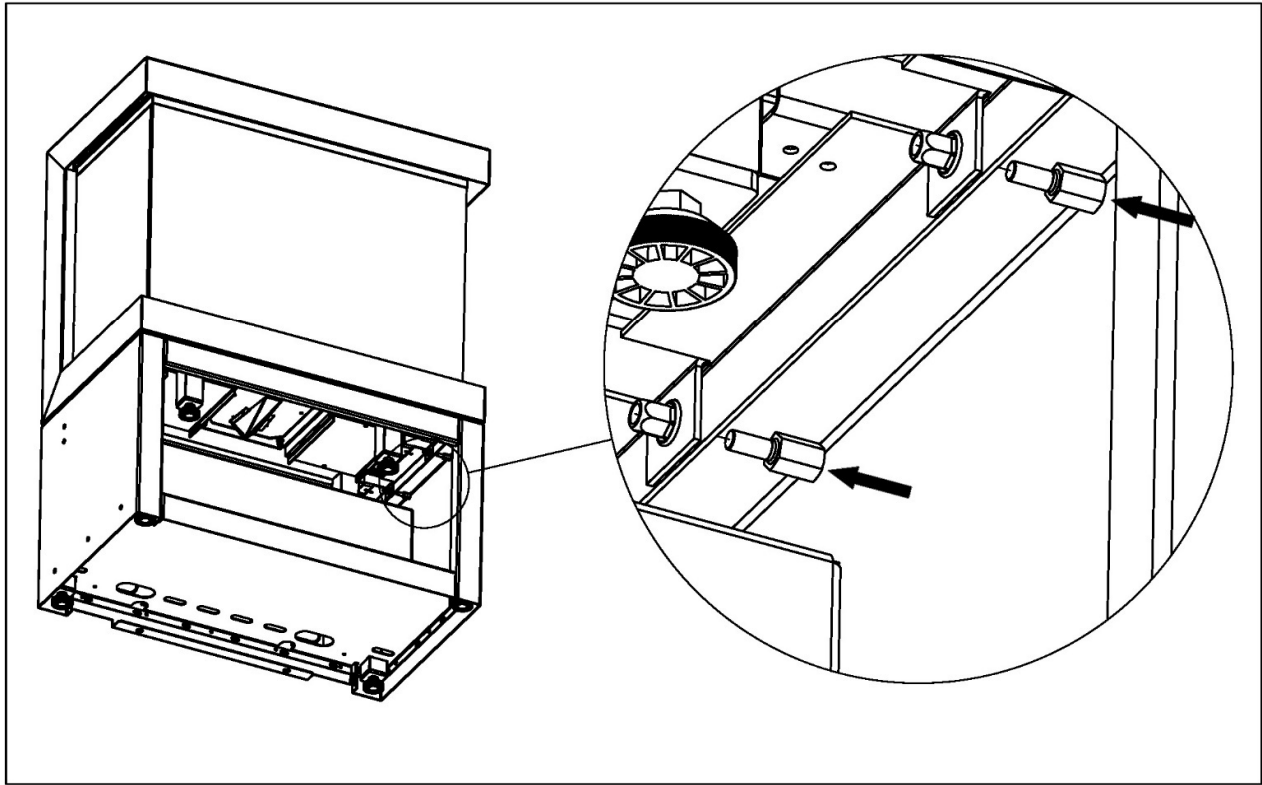

Figure (8)

Third Trip to Site: Startup

- Perform a visual inspection to confirm that all work was completed correctly and per specification.
- Confirm that gas and electrical are properly connected and live.
- Remove the screen safety barrier and inner glass and clean the inside of the fireplace.
- Install media as specified in the "Interior Design Media" section.
- Confirm media is set up per specification.
- Confirm the fireplace is operating properly.
- Check remote-control setup.
- Remove protective layer from glass.
- Clean glass.
- Reinstall the glass and screen safety barrier.
- Review operation of the fireplace and remote control with the owner.
- Set up return visit to clean glass after the Initial Burning Period (see "Post-Installation" section below).

Working with Glass Panels

Inner glass panel is 5mm ceramic glass. For fireplaces with a double glass heat barrier, exterior glass panel is 3/16" tempered glass.

Silicone comes pre-applied to any glass-to-glass connections (multi-sided models), on both sides of the glass. Keep the following guidelines in mind when handling silicone and glass panels:

The purpose of the silicone is to create a gasket, not to "glue" the glass panels together. When placing glass panels, ensure that the glass is fully in place and that the silicone is filling the space between the glass panels. Place the front (or center) panel in place first and then slide the side panel into place so that the silicone edge touches the glass edge.

- Re-apply silicone only if the original silicone is damaged (Rutland 500[®] Clear Silicone is recommended).
- If new silicone is applied, cure time is 24 hours before operation of the fireplace.
- Do not use silicone to seal the glass after it is in place.
- Always use appropriate materials and cleaning agents to clean glass. Ammonia free glass cleaners and/or ceramic glass cleaners are recommended.

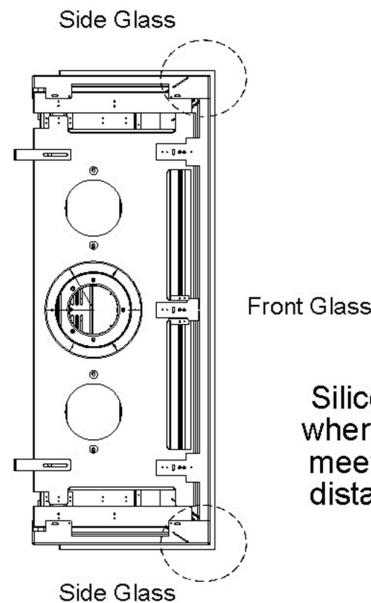

Glass Seal Assembly Diagram

(Note: Actual unit will look different than the fireplace shown in the diagram.)

Post-Installation

Complete the following post-installation steps upon 4th trip to site.

Initial Burning Period

There is a 12-hour minimum burning period following installation of the fireplace. This 12-hour period must include a minimum of 4 consecutive hours of continuous burning. During this time, the owner or installer may notice:

- The glass developing a white or “cloudy” residue.
- An unusual smell

Both the residue and the smell are due to the paint on the fireplace metal heating and “burning off”. This is normal. The cloudiness and odor will disappear after the 12-hour period elapses and the installer returns to service the fireplace and complete startup.

Final Inspection Procedure

When the 12-hour burning period is complete, the installer must return and perform the final inspection, which includes:

- Cleaning the glass with a ceramic glass cleaner (otherwise the white residue will remain)
- Checking the interior media setup
- Checking for gas leaks
- Adjusting the restrictor (if necessary)
- Performing an overall check to make sure that everything is working properly.

When these activities are complete, initial startup is concluded and the fireplace may be operated by the owner.

Final Checks and User Instruction

Before releasing the fireplace to the customer for use without installer supervision, the installer must ensure that the fireplace is burning correctly. In addition, the installer must review and explain the following to the owner:

- Safety warnings
- Fireplace operation
- Warranty requirements
- Maintenance requirements
- Glass is hot during and after operation.
- If any questions or concerns arise, owner must contact the local Ortal dealer/installer for support.

→ Clearances

Wall-Mounted Fireplace Clearances

Keep the following areas clear to specified materials:

- **1-inch** clearance around the vent pipe to any material.
- **12-inch** clearance directly above the fireplace to any material. This does not apply to the wall behind the fireplace and extending upward. It only applies directly above the fireplace.
- **12-inch** clearance from the screen heat barrier to non-combustible materials. This only applies directly in front of the screen, not above or below.
- **40-inch** clearance from the screen heat barrier to combustible materials. This only applies directly in front of the screen, not above or below.
- **6-inch** clearance from the bottom of the fireplace (not including decorative skirt) to the floor. The floor may be combustible material.
- **1/2-inch** clearance from the right and left sides of the fireplace (not glass) to any material.

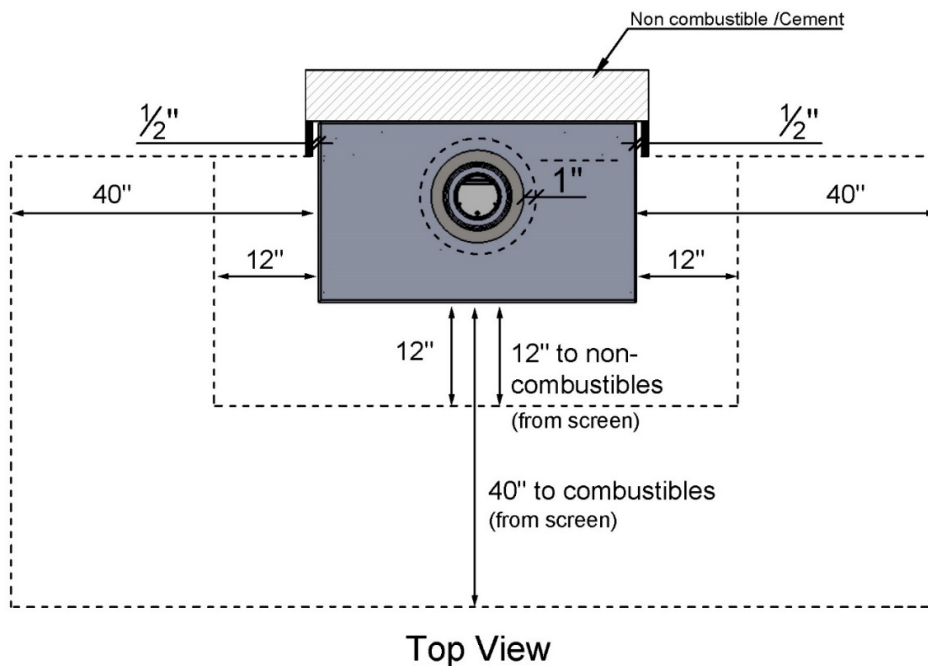
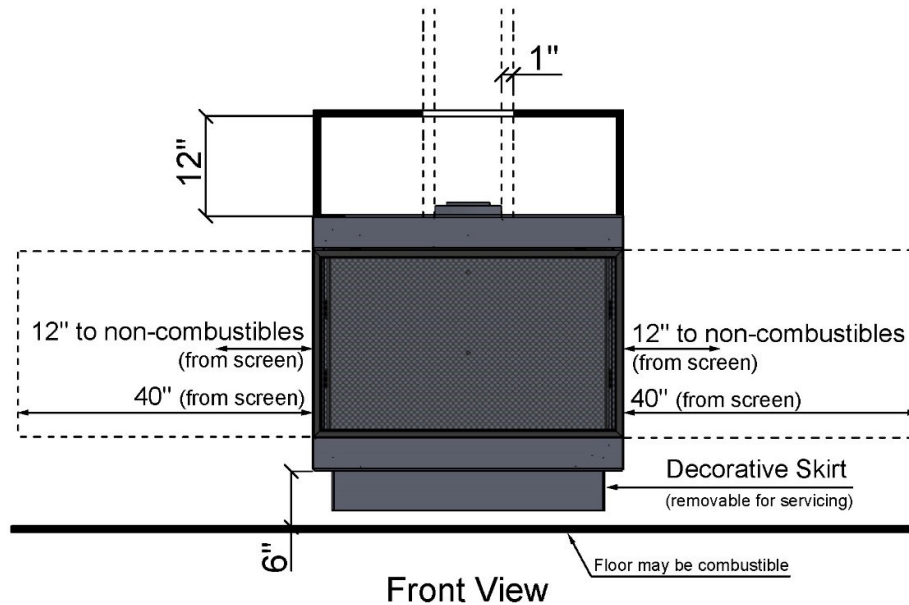

Base-Mounted Fireplace Clearances

Keep the following areas clear to specified materials:

- **1-inch** clearance around the vent pipe to any material.
- **1-inch** clearance from the back of the fireplace to any material.
- **4-inch** clearance directly above the fireplace to any material. This does not apply to the wall behind the fireplace and extending upward. It only applies directly above the fireplace.
- **12-inch** clearance from the screen heat barrier to non-combustible materials. This only applies directly in front of the screen, not above or below.
- **40-inch** clearance from the screen heat barrier to combustible materials. This only applies directly in front of the screen, not above or below.
- **Zero-clearance** from the decorative base to the floor. The base may sit directly on combustible material. Material must be able to bear the weight of the fireplace.

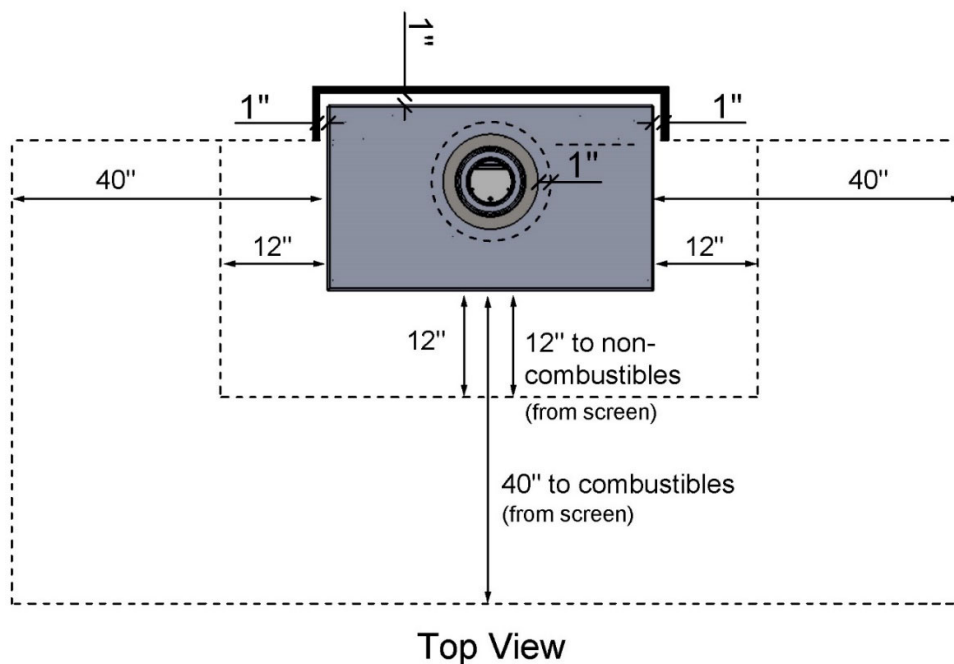
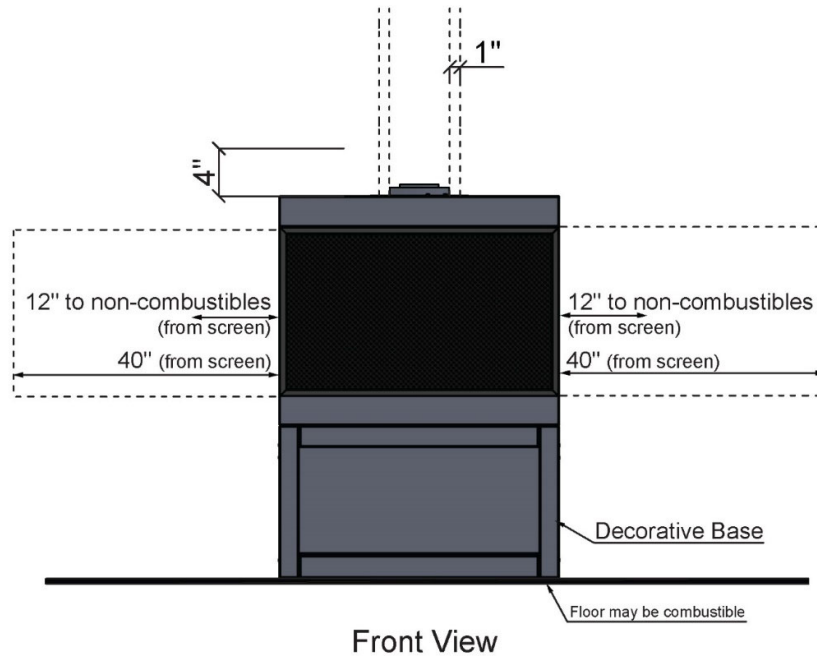

Decorative Skirt Removal

To access the gas and electrical components, the decorative skirt attached to the bottom of the fireplace must be removed. Follow the instructions below for skirt removal.

NOTE: To reinstall the skirt, perform the steps below in reverse order.

Step 1

Remove the two screws which are holding the skirt form each side as shown in figure (1).

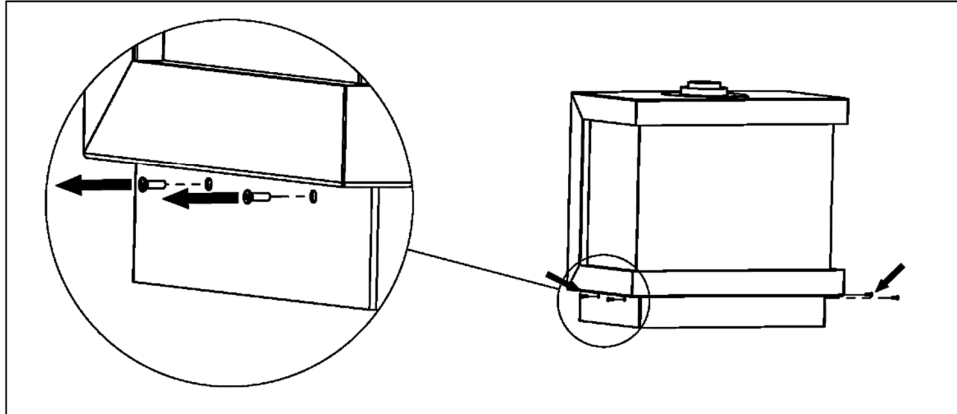

Figure(1)

Step 2

Pull the skirt and remove as shown in figure (2).

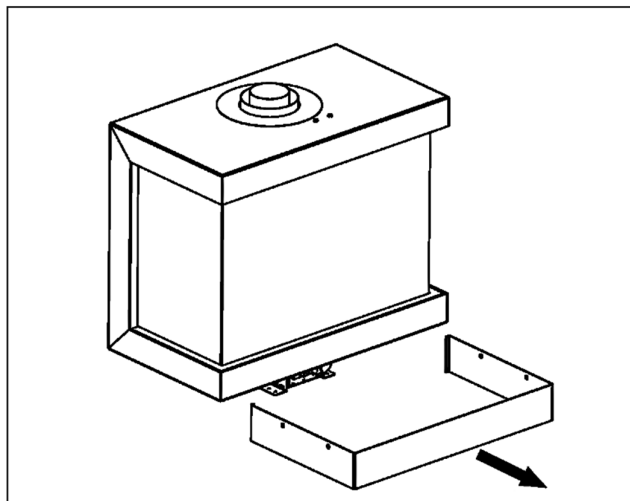

Figure(2)

Screen Installation/Removal

The instructions below are general and apply to all multi-sided fireplaces with framed screens.

Screen Removal

Step 1

Pull front-facing screen out from the bottom until the bottom comes free from the fireplace frame.

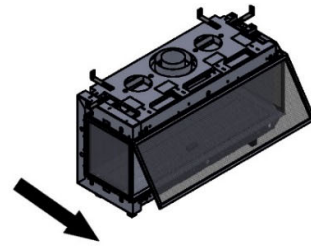

Step 2

Pull screen down until the top comes free from the fireplace frame.

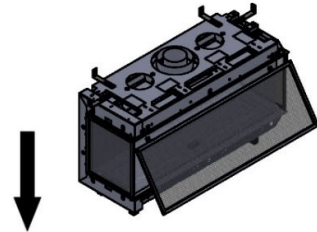

Step 3

Pull screen away and place in a safe area where it cannot get damaged.

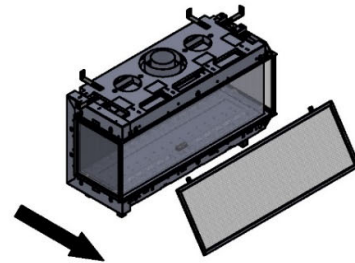

Step 4

Pull left side screen out from the bottom until the bottom comes free from the fireplace frame.

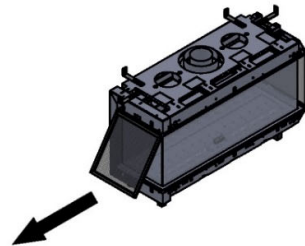

Step 5

Pull screen down until the top comes free from the fireplace frame.

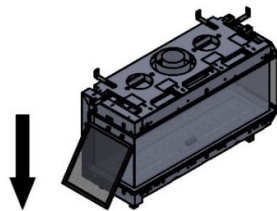

Step 6

Pull screen away and place in a safe area where it cannot get damaged.

Repeat steps 4-6 for right side screen.

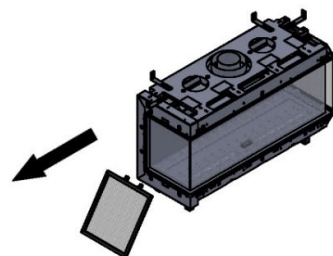

Screen Installation

Step 1

Begin installation with right or left side screen. Insert top of screen into the fireplace viewing area until the magnet on the top of the screen meets the top glass bracket.

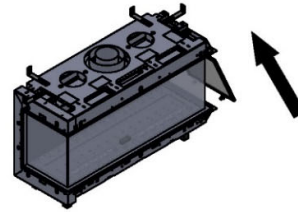

Step 2

Push screen upward until the top of the screen meets the fireplace frame.

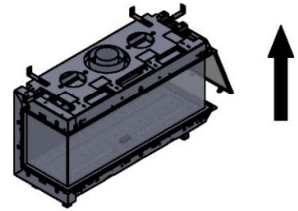

Step 3

Connect the magnets on the bottom of the screen with the bottom of the fireplace. Screen is now in place.

Repeat steps 1-3 for remaining side screen.

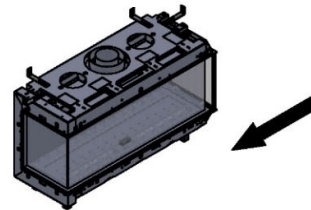

Step 4

Insert the top of the screen into the fireplace viewing area until the magnet on the top of the screen meets the top glass bracket.

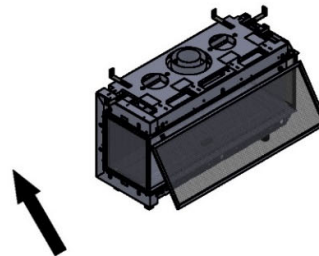

Step 5

Push screen upward until the top of the screen meets the fireplace frame.

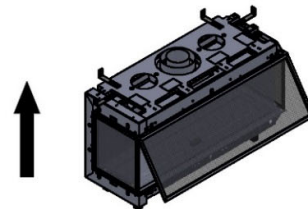

Step 6

Connect the magnets on the bottom of the screen with the bottom of the fireplace. Screen is now in place.

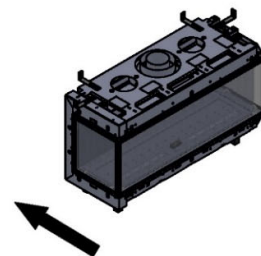

Venting

General Venting Requirements

The fireplace operates using a direct vent system and requires co-axial direct vent pipe. The fireplace must be properly connected to an approved vent system. Venting is not provided with the fireplace and must be sourced from one of the approved vent manufacturers mentioned in the table below. Proper installation, use, and maintenance of venting is determined by and can be acquired from the vent manufacturer.

Vent Requirements			
Fireplace Model	Direct Vent Type	Vent Size	Approved Vent Manufacturers
Stand Alone 40 TS Stand Alone 75 TS	Passive Vent (standard)	4x6 co-axial direct vent pipe (4" interior, 6 5/8" exterior)	DuraVent: Direct Vent Pro ICC: EXCELDirect BDM: Pro-Form Direct Vent System Selkirk: Direct-Temp System Olympia: Ventis
	Enervex Power Vent (optional)		
Stand Alone 110 TS	Passive Vent (standard)	5x8 co-axial direct vent pipe (5" interior, 8" exterior)	DuraVent: Direct Vent Pro ICC: EXCELDirect BDM: Pro-Form Direct Vent System Selkirk: Direct-Temp System Olympia: Ventis
	Enervex Power Vent (optional)		

Power Vent: a fan-assisted direct vent system that boosts airflow for vent configurations with too much constriction. Review the "Vent Configuration" section to determine if your fireplace needs a power vent.

 **POWER VENT NOTE:** Stand Alone model fireplaces are approved for power-venting with an Enervex system only. Ortal-manufactured power vents cannot be used with Stand Alone fireplaces. See Ortal's Enervex RS Power Vent Manual for more details on power venting with an Enervex power vent.

 **TERMINATION CAP NOTE:** Low Profile Termination Cap and Sconce Termination Cap can negatively impact flame appearance and are not recommended for use with the fireplace.

 **WARNING:** Do not combine vent components from different vent manufacturers. Please follow the manufacturer's instructions for vent system installation.

→ Vent Configurations

The following sections provide information for calculating vent configuration distances and elbows. For vent configurations that cannot conform to these guidelines, consider the Enervex RS Power Vent System, or contact Ortal for assistance. Power Vent information can be found in the Ortal Enervex RS Power Vent System Manual.

Please consider the following guidelines when determining vent configuration:

Elbows

- **Maximum Elbows:** Up to four 90° elbows can be used in the vent configuration. Two 45° elbows = one 90° elbow.
 - **45° Vertical Offset Exception:** Two 45° elbows in the vertical plane with a diagonal run in between is equal to **0 elbows**. They are not counted with other elbows in the vent configuration. This offset exception is applicable immediately on the top of the fireplace and anywhere else within the vent configuration.
The diagonal run between the two 45° elbows must be included when calculating vertical and horizontal distances.
 - **45° Horizontal Offset:** Two 45° elbows that begin and end in the horizontal plane, with a diagonal run in between, is equal to **one 90° elbow**. Additionally, **3 feet** must be reduced from the total allowable horizontal run.
The diagonal run between the two 45° elbows must be included when calculating vertical and horizontal distances
- **Exceeding two 90° Elbows:** For more than two 90° elbows, the minimum total vertical rise is **6 feet** for 110 models. This does not apply to 40-75 models.
- **Flat 90° Elbows:** For every flat 90° elbow (a 90° elbow that stays in the horizontal plane), **6 feet** must be reduced from the total allowable horizontal run. Up to two flat elbows are allowed.
 - Example: If max allowable horizontal run is 24 feet and 1 flat elbow is added, max run is reduced to 18 feet.
- **3rd 90° Elbow in the Vertical Plane:** The 3rd elbow in the vertical plane reduces **3 feet** from total allowable horizontal run. Do not include flat elbows when determining which 90° elbow in your configuration is 3rd in the vertical plane.

 **Exception:** If the 3rd 90° elbow in the vertical plane turns the vent direction from horizontal to vertical, the total allowable horizontal run does not require a 3-foot reduction.

Diagonal Runs

- Calculating Diagonal Runs (D):** Diagonal (45°) vent runs have an equal combination of vertical and horizontal aspects. To include diagonal portions of your desired vent configuration when determining overall vent limitations, divide the diagonal distance in half. Add this value to the total vertical rise and total horizontal run distances in your vent configuration. Include these values when utilizing the Vent Configuration Tables below.
 - Example: 6 feet diagonal run = 3 feet vertical rise & 3 feet horizontal run

Other

- V Minimum:** This is the minimum amount of vertical rise required before the first *completely* horizontal (not diagonal) run.
- Any vent configuration that does not meet these parameters requires Ortal's review and approval.

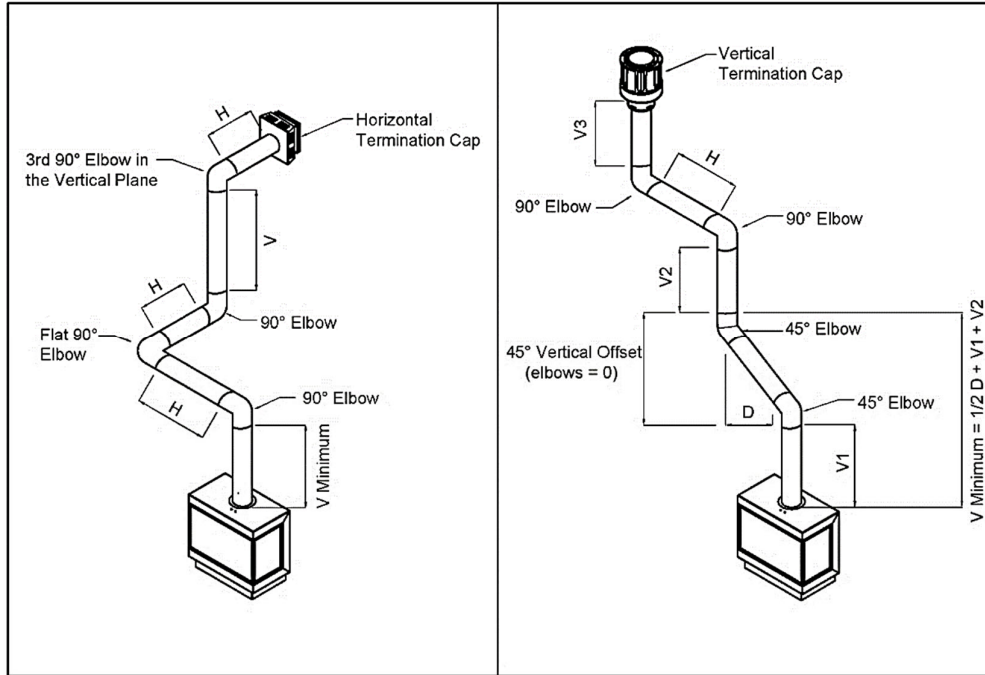

! TERMINATION CAP NOTE: Low Profile Termination Cap and Sconce Termination Cap can negatively impact flame appearance and are not recommended for use with the fireplace.

Maximum Allowable Horizontal Runs

Stand Alone 40 TS	
V minimum = 0 feet	
Vertical (V)	Max Horizontal (H)
0 ft	6 ft
1 ft	12 ft
3 ft	21 ft
6 ft	24 ft
9 ft	30 ft
12 ft	30 ft
15 ft	24 ft
18 ft	21 ft
21 ft	18 ft
24 ft	15 ft
27 ft	12 ft
30 ft	12 ft
33 ft	12 ft
36 ft	4 ft
44 ft	0 ft

Stand Alone 75 TS	
V minimum = 0 feet	
Vertical (V)	Max Horizontal (H)
0 ft	6 ft
1 ft	12 ft
3 ft	21 ft
6 ft	24 ft
9 ft	30 ft
12 ft	30 ft
15 ft	24 ft
18 ft	21 ft
21 ft	18 ft
24 ft	15 ft
27 ft	12 ft
30 ft	12 ft
33 ft	12 ft
36 ft	4 ft
44 ft	0 ft

Stand Alone 110 TS	
V minimum = 3 feet	
Vertical (V)	Max Horizontal (H)
N/A	N/A
N/A	N/A
3 ft	12 ft
6 ft	24 ft
9 ft	30 ft
12 ft	30 ft
15 ft	30 ft
18 ft	27 ft
21 ft	24 ft
24 ft	21 ft
27 ft	21 ft
30 ft	21 ft
33 ft	21 ft
36 ft	12 ft
44 ft	0 ft

! CHART NOTE: Do not include the space elbows take up when calculating your vertical and horizontal distances.

Vent Restrictors

The restrictor sizing tables in this section determine the recommended restrictor for your vent configuration. These tables show Ortal's recommendations only. The environment, gas type, and other factors may affect the best restrictor choice.

How to use the "Recommended Restrictor" tables:

1. Find the total vertical rise in your vent configuration along the y-axis.
2. Find the horizontal run in your vent configuration along the x-axis.
3. Follow the desired rise and run values within the table until they meet. This value is the recommended restrictor size (in inches) for your vent configuration.

Legend:

X: Vent configuration is not allowed. Power vent required.

0: No restrictor required.

Numbers other than 0: Represents the recommended restrictor (by width).

Restrictor Sizes:

- 20mm (0.79")
- 30mm (1.18")
- 40mm (1.57")
- 50mm (1.97")
- 70mm (2.75")
- 85mm (3.35")

Stand Alone 40 & 75 TS												
V Minimum = 0 Feet												
Total Vertical Vent Rise	44'	1.97"	X	X	X	X	X	X	X	X	X	X
	33'	1.97"	1.97"	1.97"	1.97"	1.57"	X	X	X	X	X	X
	30'	1.97"	1.97"	1.97"	1.97"	1.57"	X	X	X	X	X	X
	27'	1.97"	1.97"	1.97"	1.97"	1.57"	X	X	X	X	X	X
	24'	1.97"	1.97"	1.97"	1.97"	1.57"	1.18"	X	X	X	X	X
	21'	1.97"	1.97"	1.97"	1.97"	1.57"	1.18"	0	X	X	X	X
	18'	1.97"	1.97"	1.97"	1.57"	1.57"	1.18"	0.79"	0	X	X	X
	15'	1.57"	1.57"	1.57"	1.57"	1.18"	1.18"	0.79"	0	0	X	X
	12'	1.57"	1.57"	1.57"	1.18"	1.18"	0.79"	0	0	0	X	X
	9'	1.57"	1.57"	1.18"	1.18"	0.79"	0	0	0	0	X	X
	6'	1.18"	1.18"	0.79"	0.79"	0	0	0	0	0	X	X
	3'	0	0	0	0	0	0	0	0	0	X	X
	0'	0	0	0	0	0	X	X	X	X	X	X
	0'	3'	6'	9'	12'	15'	18'	21'	24'	27'	30'	33'

Stand Alone 110 TS												
V Minimum = 3 Feet												
Total Vertical Vent Rise	44'	2.75"	X	X	X	X	X	X	X	X	X	X
	33'	2.75"	1.97"	1.97"	1.97"	X	X	X	X	X	X	X
	30'	2.75"	1.97"	1.97"	1.97"	X	X	X	X	X	X	X
	27'	2.75"	1.97"	1.97"	1.97"	X	X	X	X	X	X	X
	24'	2.75"	2.75"	2.75"	1.97"	X	X	X	X	X	X	X
	21'	2.75"	2.75"	1.97"	1.97"	1.57"	1.18"	X	X	X	X	X
	18'	1.97"	1.97"	1.97"	1.57"	1.57"	1.18"	0	X	X	X	X
	15'	1.97"	1.97"	1.97"	1.57"	1.57"	1.18"	0	0	X	X	X
	12'	1.97"	1.97"	1.57"	1.57"	1.18"	1.18"	0	0	X	X	X
	9'	1.57"	1.57"	1.18"	1.18"	0	0	0	0	0	X	X
	6'	1.18"	0	0	0	0	0	0	0	0	X	X
	3'	0	0	0	0	0	X	X	X	X	X	X
	0'	X	X	X	X	X	X	X	X	X	X	X
	0'	3'	6'	9'	12'	15'	18'	21'	24'	27'	30'	33'

Vent Clearances

The following clearances apply to the vent system regardless of vent manufacturer.

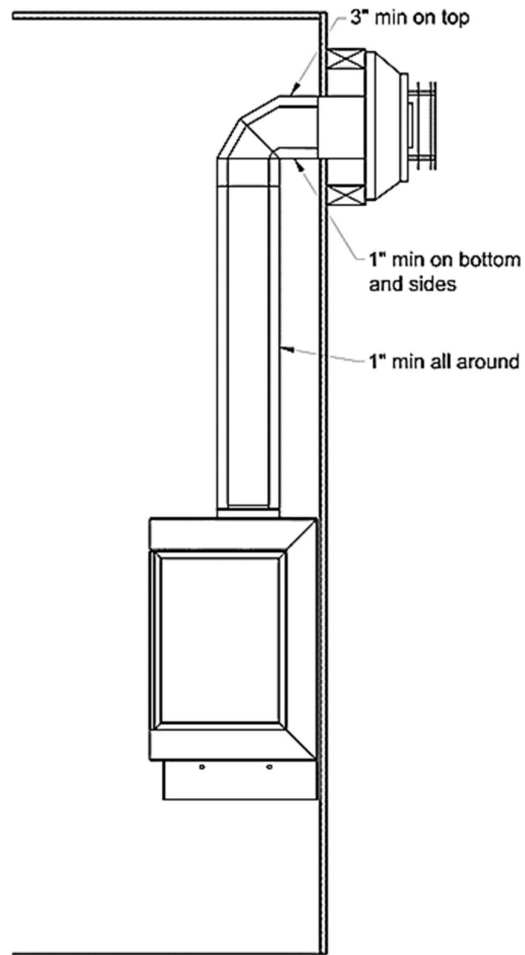

Vent Clearances	
Sides: 1"	Applies to entire circumference when venting is oriented vertically. Clearance is to any material.
*Top: 3"	
Bottom: 1"	
Applies to venting oriented horizontally or at an angle. Clearance is to any material.	

***Exception:** Wall thimble top clearance to any material is 1".

Vent Termination

Horizontal Termination Clearances

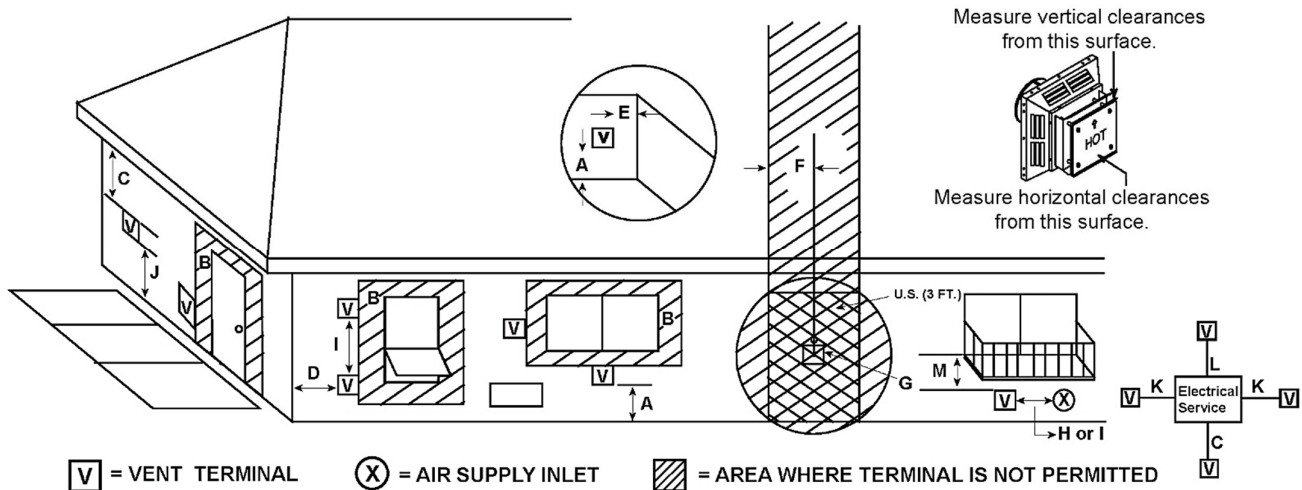

Location	Country	Minimum Clearance	Description
A	US & Canada	12 inches	Clearance above grade, veranda, porch, deck, or balcony. NOTE: On private property where termination is less than 7 feet above a sidewalk, driveway, deck, porch, veranda, or balcony, use of a listed cap shield is suggested.
B	US	≤ 50,000 BTU: 9 inches > 50,000 BTU: 12 inches	Clearance to an operable window or door. NOTE: Zero clearance to an inoperable window or door.
	Canada	12 inches	
C	US & Canada	24 inches	Vertical clearance to a ventilated soffit located above the vent termination.
		18 inches	Vertical clearance to an unventilated soffit located above the vent termination.
		42 inches	Vertical clearance to vinyl clad soffits and below electrical service.
D	US & Canada	9 inches	Clearance to an outside corner.
E	US & Canada	6 inches	Clearance to an inside corner.
	US	N/A	Not to be installed above a gas meter/regulator assembly within 3 feet (90 cm) horizontally from the center-line of the regulator.
Canada	3 feet		
G	US & Canada	3 feet	Clearance to gas service regulator vent outlet.
H	US	9 inches	Clearance to a non-mechanical air supply inlet to the building or the combustion air inlet to any other appliance. NOTE: Termination in a covered alcove space (spaces open only on one side and with an overhang) are permitted with the dimensions specified for vinyl or non-vinyl siding and soffits. 1. There must be 3 feet minimum between termination caps. 2. All mechanical air intakes within 10 feet of a termination cap must be a minimum of 3 feet below the termination cap. 3. All gravity air intakes within 3 feet of a termination cap must be a minimum of 1 foot below the termination cap.
	Canada	12 inches	
I	US	3 feet	Clearance to a mechanical (powered) air supply inlet. NOTE: Termination in a covered alcove space (spaces open only on one side and with an overhang) are permitted with the dimensions specified for vinyl or non-vinyl siding and soffits. 1. There must be 3 feet minimum between termination caps. 2. All mechanical air intakes within 10 feet of a termination cap must be a minimum of 3 feet below the termination cap. 3. All gravity air intakes within 3 feet of a termination cap must be a minimum of 1 foot below the termination cap.
	Canada	6 feet	
J*	US & Canada	7 feet	Clearance above paved sidewalk or a paved driveway located on public property. NOTE: On private property where termination is less than 7 feet above a sidewalk, driveway, deck, porch, veranda, or balcony, use of a listed cap shield is suggested. *a vent shall not terminate directly above a sidewalk or paved driveway which is located between two single family dwellings and serves both dwellings.
K	US & Canada	6 inches	Clearance from sides of electrical service. NOTE: Location of the vent termination must not interfere with access to the electrical service.
L	US & Canada	12 inches	Clearance above electrical service. NOTE: Location of the vent termination must not interfere with access to the electrical service.

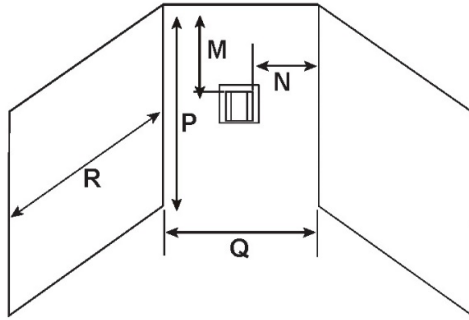

Covered Alcove: spaces open only on one side and with an overhang

Horizontal Termination Clearances Continued: Covered Alcove Application				
Location	Country	Minimum Clearance	Description	
COVERED ALCOVE APPLICATION	M	US & Canada	16 inches	Clearance under non-vinyl veranda, porch, deck, balcony, or overhang. NOTE: Termination in a covered alcove space is permitted with the dimensions specified. 1. There must be 3 feet minimum between termination caps. 2. All mechanical air intakes within 10 feet of a termination cap must be a minimum of 3 feet below the termination cap. 3. All gravity air intakes within 3 feet of a termination cap must be a minimum of 1 foot below the termination cap.
	N	US & Canada	6 inches	Non-vinyl sidewalls.
			12 inches	Vinyl sidewalls.
	P	US & Canada	8 feet	Alcove height.
	Q	US & Canada	See table below.	Alcove width (dependent on number of caps in the space).
	R	US & Canada	See table below.	Alcove depth (dependent on number of caps in the space).

# Vent Caps	Q _{MINIMUM}	R _{MAXIMUM}
1 vent cap	3 feet	2 x Q _{ACTUAL}
2 vent caps	6 feet	1 x Q _{ACTUAL}
3 vent caps	9 feet	² / ₃ x Q _{ACTUAL}
4 vent caps	12 feet	¹ / ₂ x Q _{ACTUAL}
Q_{MIN} = # vent caps x 3		R_{MAX} = (²/_{# vent caps}) x Q_{ACTUAL}

! HORIZONTAL TERMINATION CAP CLEARANCES - NOTES:

- If exterior walls are finished with vinyl siding, it is *required* that a vinyl protector kit be installed.
- Vent system termination is not permitted in screened porches.
- Vent system termination is permitted in porch areas with two or more sides open. You must follow all side walls, overhang and ground clearances as stated.
- Termination caps may be hot. Consider their proximity to doors or other traffic areas.

! TERMINATION CAP NOTE: A Sconce Termination Cap can negatively impact flame appearance and is not recommended for use with the fireplace.

Vertical Termination Clearances

Minimum Height From Roof To Lowest Discharge Opening

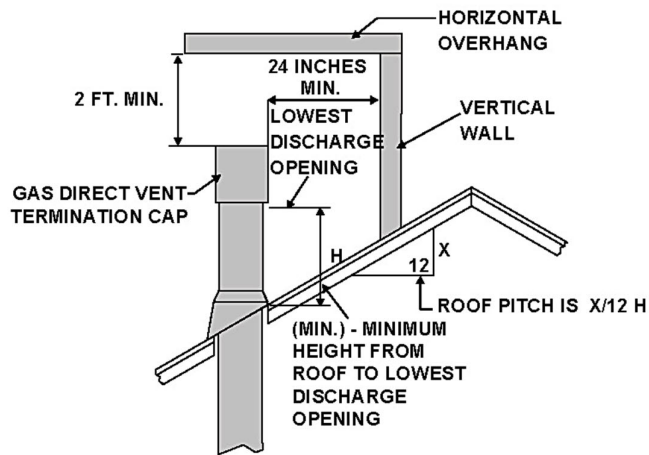

Roof Pitch	H (Min.) Ft.
Flat to 6/12.....	1.0*
Over 6/12 to 7/12.....	1.25*
Over 7/12 to 8/12.....	1.5*
Over 8/12 to 9/12.....	2.0*
Over 9/12 to 10/12.....	2.5*
Over 10/12 to 11/12.....	3.25
Over 11/12 to 12/12.....	4.0
Over 12/12 to 14/12.....	5.0
Over 14/12 to 16/12.....	6.0
Over 16/12 to 18/12.....	7.0
Over 18/12 to 20/12.....	7.5
Over 20/12 to 21/12.....	8.0

*H min. may vary depending on regional snowfall. Refer to local codes.

Staggered Termination Caps

A	B
6 in. (minimum) up to 24 in.	18 in. minimum
24 in. and over	0 in. minimum

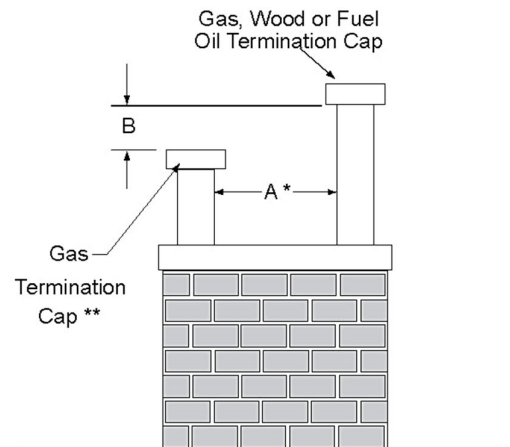

* If using decorative cap cover(s), this distance may need to be increased. Refer to the installation instructions supplied with the decorative cap cover.

** In a staggered installation with both gas and wood or fuel oil terminations, the wood or fuel oil termination cap must be higher than the gas termination cap.

Notes:

1. Maintain a minimum of 2 feet clearance between edge of vertical termination and perpendicular wall.
2. If terminating near window, keep minimum of 2 feet clearance between window and vent termination.
3. All mechanical air intakes (such as an Enervex power vent) within 10 feet of a termination cap must be a minimum of 3 feet below the termination cap.
4. All gravity air intakes within 3 feet of a termination cap must be a minimum of 1 foot below the termination cap.

! NOTE: This chart does not apply to a chimney shroud application. See the "Chimney Shroud" section on the next page for more information.

! TERMINATION CAP NOTE: A Low Profile Termination Cap can negatively impact flame appearance and is not recommended for use with the fireplace.

Chimney Shroud

Top Open

Keep a minimum **6-inch** clearance around the diameter of the cap's side edge and extending above and below the cap.

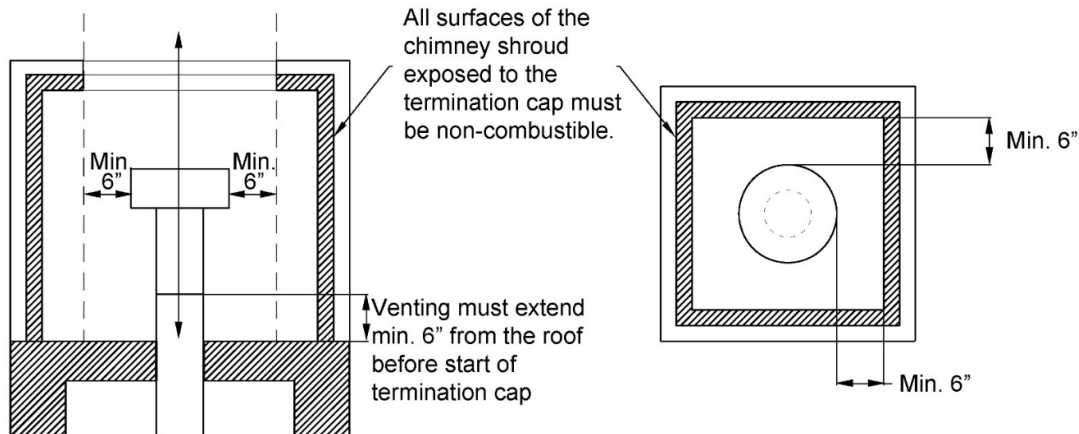

Sides Open

Keep a minimum **6-inch** clearance around the diameter of the cap's side edge, and a minimum **10-inch** clearance above the top of the cap. For openings in the shroud, make sure to allow for enough air flow space to release the exhaust gases and allow the vent to operate properly.

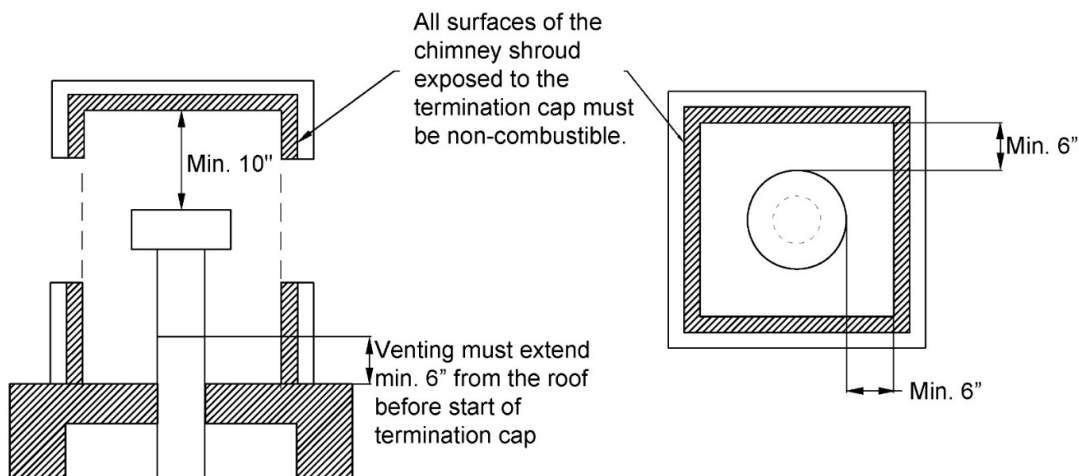

Vent Installation

Venting must be installed to meet the requirements as detailed in the following sections in conjunction with the vent system manufacturer's installation instructions. Venting must be supported by the structural surrounding and not by the fireplace. Each offset (elbow) must be strapped to reduce movement or possible disconnection.

The first section of venting must be secured to the fireplace starter collar with a minimum of 3 sheet metal screws no longer than $\frac{1}{2}$ ". DO NOT use silicone to seal the sections. If sealing is required by the vent manufacturer or local code, use Mil-Pac sealant.

WARNING: Do not combine vent components from different vent manufacturers. Please follow the manufacturer's instructions for vent system installation.

Vent Maintenance

Regular inspection of the vent system by a qualified service technician is recommended every six months. The following maintenance routing is recommended:

- Inspect for excessive condensation, e.g., water droplets forming in the inner lining, and subsequently dripping from the joints. This can cause corrosion in the system.
- Check for corrosion in areas exposed to the elements. Components with rust spots or holes must be immediately replaced.
- Ensure that there is no foreign material in the vents. Survey by removing the cap and shining a light down the vent.
- If possible, check all vent joints to make sure nothing has been disturbed or loosened.

Gas

The fireplaces are approved for use with natural gas (NG) or propane (LP) only. No other fuel types are permitted.

Gas Pressures

Fireplace Series	Burner	Gas Type	Inlet Pressure		Manifold Pressure	Heat Input (BTU/hr)		Orifice Size*
			Min	Max		Min	Max	
Stand Alone 40 TS	30 Single	Natural Gas	7.0	10.0	3.2	10,419	23,670	650
		Propane	11.0	13.0	10.9	12,841	21,073	220
Stand Alone 75 TS	45 Single	Natural Gas	7.0	10.0	4.7	16,147	29,100	650
		Propane	11.0	13.0	9.5	15,627	28,348	320
Stand Alone 110 TS	100 Single	Natural Gas	7.0	11.0	5.6	22,798	37,167	1200
		Propane	11.0	13.0	10.0	25,113	35,316	380

NOTE: It can take up to 20 minutes for the flames to turn yellow.

Routing the Gas Line

Wall-Mounted Fireplace

The gas and electrical components are attached to the pilot on a flexible gas line directly under the fireplace. The removable skirt below the fireplace is open on the back and bottom to allow for easy service access.

To know exactly where to route the gas line, you must know where the fireplace is going to be installed. For a fireplace being installed on a wood-framed wall, refer to Step 4 on page 16. For a fireplace being installed on a concrete or masonry wall, refer to Step 3 on page 19.

Correctly size and route the gas supply line to the back bottom side of the fireplace as shown in the figure below. Gas must be routed per the requirements outlined in the latest edition of the National Fuel Gas Code, NFPA 54 (USA) or CAN/CSA-B1491 (Canada).

A gas shut-off valve and a 12" gas flex connector are provided with every fireplace. The location of the gas shut-off valve is dependent on local codes and requirements. Check with your authority having jurisdiction for more information.

WARNING: The main gas valve must be installed to allow complete disconnection of the fireplace from the gas supply piping system for servicing purposes.

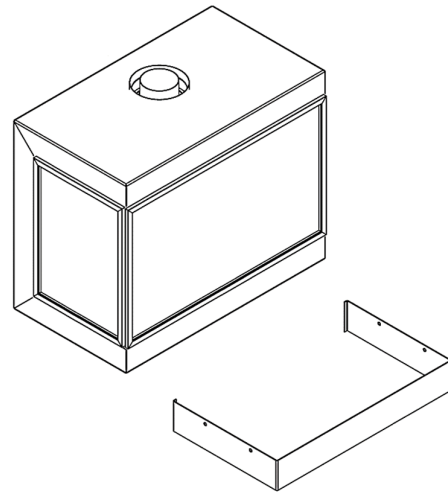

Removable Skirt

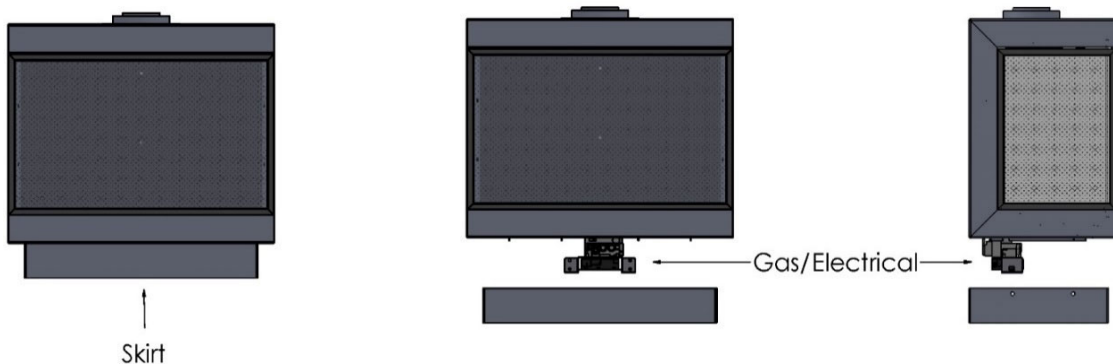

NOTE: The decorative skirt will hide the gas/electrical components once reinstalled.

Stand Alone 40 TS Skirt height: 3 ¹⁵/₁₆"

Stand Alone 75 TS Skirt height: 3 ¹⁵/₁₆"

Stand Alone 110 TS Skirt height: 4 ⁷/₁₆"

Base-Mounted Fireplace

For a base-mounted fireplace, route the gas through one of the two gas knockouts located on the back of the base. See diagrams below for details.

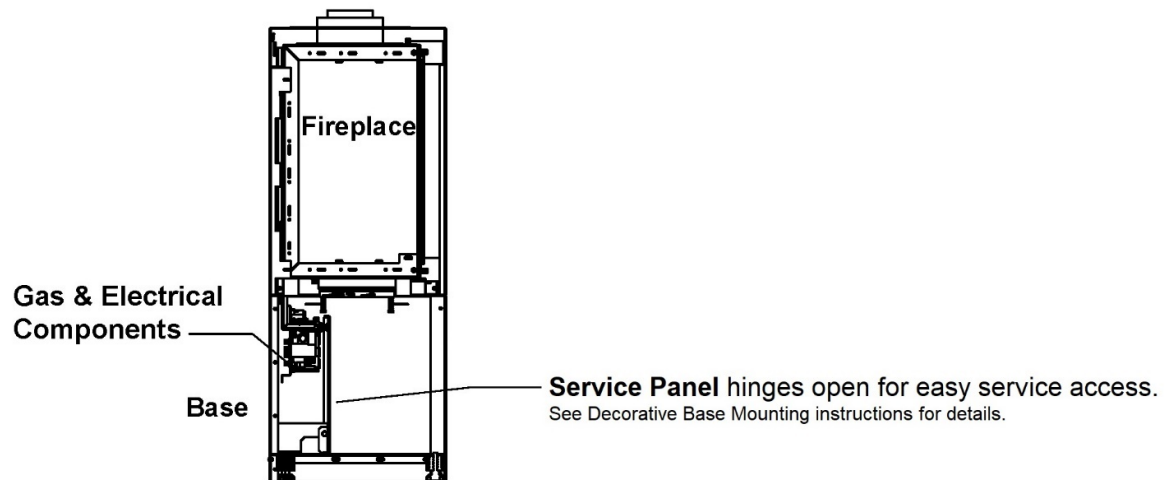

Fireplace + Base - Left Side
Section View

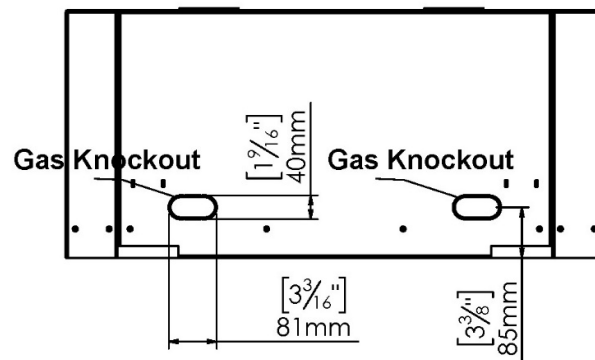

Base only - Back View

Gas Conversion

Gas conversion (NG to LP or LP to NG) of the Stand Alone series fireplaces can be done in the field. Gas conversion must only be performed by a technician who has specific authorization by Ortal to change these components. The conversion kit must be supplied by Ortal. Using parts from other manufacturers or having an unauthorized party perform the conversion will void your fireplace's warranty. Conversion instructions are supplied with the conversion kit.

Stand Alone 40 TS NG to LP Conversion Kit SKU: **GCNL300-US**

Stand Alone 40 TS LP to NG Conversion Kit SKU: **GCLN30**

Stand Alone 75 TS NG to LP Conversion Kit SKU: **GCNL45DO-US**

Stand Alone 75 TS LP to NG Conversion Kit SKU: **GCLN45**

Stand Alone 110 TS NG to LP Conversion Kit SKU: **GCNL100E-US**

Stand Alone 110 TS LP to NG Conversion Kit SKU: **GCNLP100E-US**

High Altitude Requirements

For elevations above 2,000 feet, fireplace shall be re-rated 4% for each 1,000 feet above sea level.

Electrical



WARNING: Disconnect the power supply before servicing any electrical components.

Electrical Requirements

The Stand Alone TS series fireplaces have the option to either run on 4 AA batteries or a 6-Volt AC Adapter. The fireplace should not use both the batteries and power supply at the same time.

- **4 AA Batteries:** 4 AA batteries must be installed in the electrical receiver. Batteries must be replaced annually (more frequently if fireplace is operated regularly). Failure to replace batteries may cause damage to the electrical receiver.
- **6-Volt AC Adapter:** One duplex receptacle with two outlets (not included) must be installed directly under the **bottom left** side of the fireplace (see diagram below). Maintain min. **1-inch** clearance to the back of the fireplace to the outlet. For aesthetic purposes, it is recommended to install the outlet horizontally to allow the decorative skirt to fully cover the outlet. Batteries **MUST NOT** be installed in the receiver when an AC Adapter is plugged in as this could cause operation malfunctions.

Outlet Type	Power Requirements
1 Duplex Receptacle (2 outlets) (Standard Receptacle Size = 2 3/4" x 4 1/2")	120V, 15 amp, 60Hz

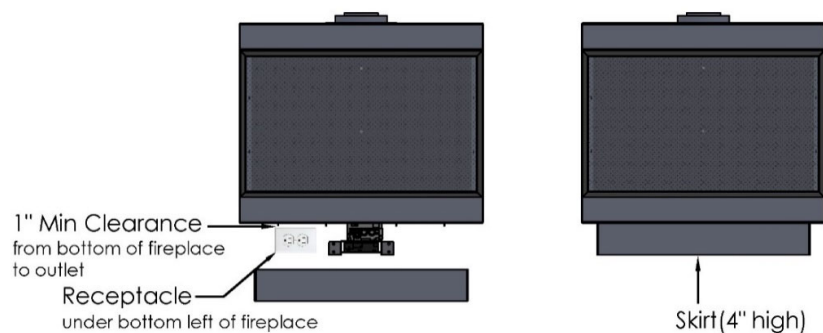

Locating the Outlet



NOTE: Any device that functions using the same radio frequency as the handset will be affected when remote-controlled handset is in use.

Power Outage

Fireplaces with a **screen heat barrier and no other optional features** (Envorex RS Power Vent or Wi-Fi) may be used with 4 AA batteries in the receiver in addition to the AC Adapter. If the batteries are used instead of the AC Adapter, the fireplace can operate in the event of a power outage to the building. Batteries must be replaced annually.

Fireplaces with power vent cannot be used with batteries. Fireplaces with Wi-Fi can still be battery-operated, but the Wi-Fi alone will not function.

Pairing the Remote and Receiver

To set up the remote-control device to operate the fireplace, follow the following guidelines to pair the remote and receiver unit on the same radio frequency.

1. Press and hold the receiver's reset button until you hear two beeps. The first beep is short, and the second beep is long. After the second beep, release the reset button.
2. Within the subsequent 20 seconds, press the following button depending on the mode of operation:
 - **10-Button Handset:** Press the  button until you see the word "CONN" and a number counting up from 1 to 8 appear on the handset display. This confirms that the synchronization and data exchange are in process.
 - **Puck Handset:** Press and hold the **-** button approximately 4 seconds.
 - **Wall Switch:** Use the 10-button handset to synch with the receiver. Once the remote and receiver are paired, the wall switch will function normally.
 - **MyFire App:** Use the 10-button handset to synch with the receiver. Once the remote and receiver are paired, the App will function normally.
3. You will hear two short beeps confirming the connection.



NOTES:

- If you hear one long beep, this indicates the connection has failed or the wiring is incorrect.
- The connection between remote and receiver only needs to be made once and is not required after changing the batteries in the remote.

Wiring Diagrams

The following diagram shows the electrical wiring required a Stand Alone Front fireplace with a screen heat barrier.

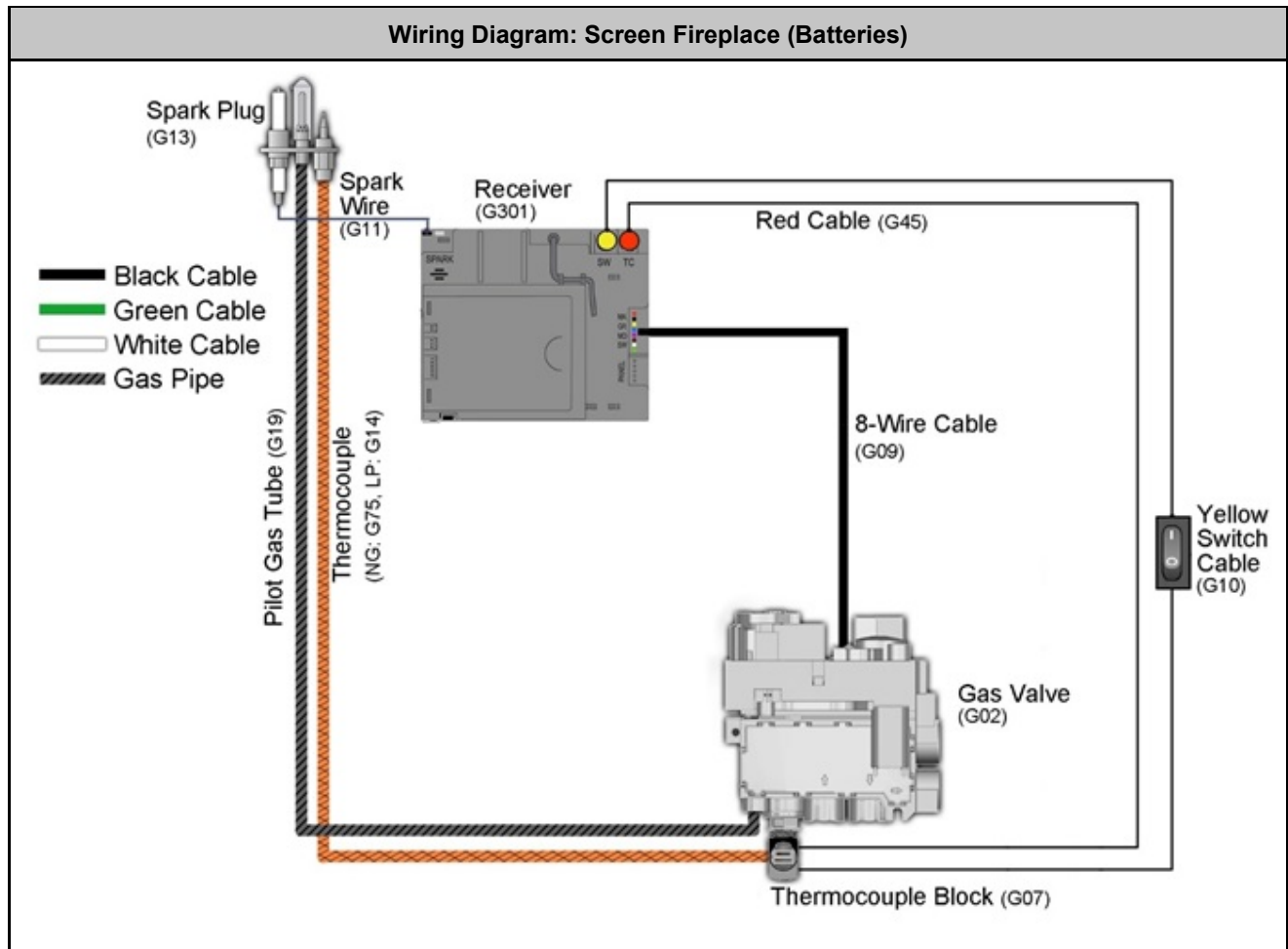

Wiring Diagram: Screen Fireplace (AC Adapter)

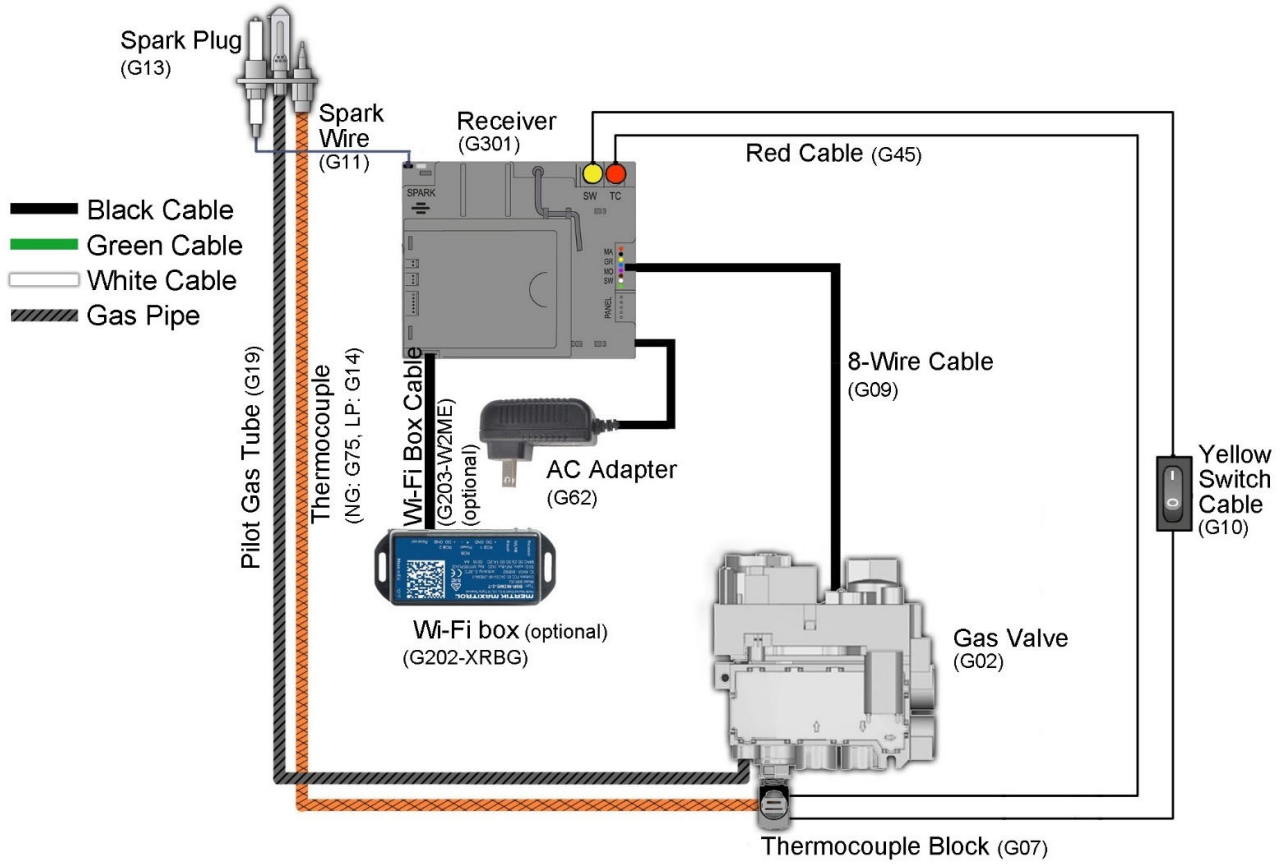

Home Automation Wiring Diagram

Use the following wiring diagram to connect fireplace control a hardwired home automation system.

Contacts Options/Operation

Ignition: Close contacts 0 (orange) and 2 (brown) simultaneously for 1 second. Fireplace automatically goes to high after ignition.

Up Flame: Close contacts 0 (orange) and 1 (red) simultaneously. The contact needs to be closed for 12 seconds to turn the motor from end-stop to end-stop.

Down Flame: Close contacts 0 (orange) and 3 (black) simultaneously. The contact needs to be closed for 12 seconds to turn the motor from end-stop to end-stop.

Off: Close contacts 0 (orange) and 2 (brown) simultaneously for 1 second.

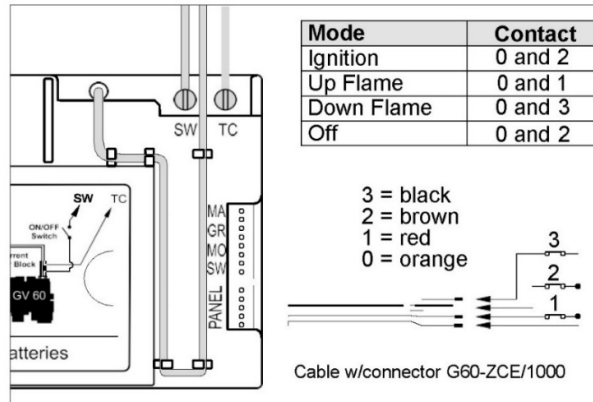

Wiring Diagram and Operation Sequence

Mode of Operation: The external source provides ON and OFF operation only. The Timer/Thermostat handset provides all other functions.

NOTICE: The Timer/Thermostat handset in Thermostatic Model controls the room temperature even if the fire is turned on by the external source. If the handset is in Manual Mode, the fire will go to High Fire in the next cycle of external operation.

NOTE: This wiring diagram is for hardwired home automation systems only and will not connect the fireplace to a wireless system.

Interior Design Media

Media Placement Guidelines

When installing media, adhere to the following general guidelines:

- Keep the media back from the pilot hood so at least one burner port is open. Crowding around the pilot hood may hinder lighting and could result in potential damage to the fireplace and surrounding area or personal injury.

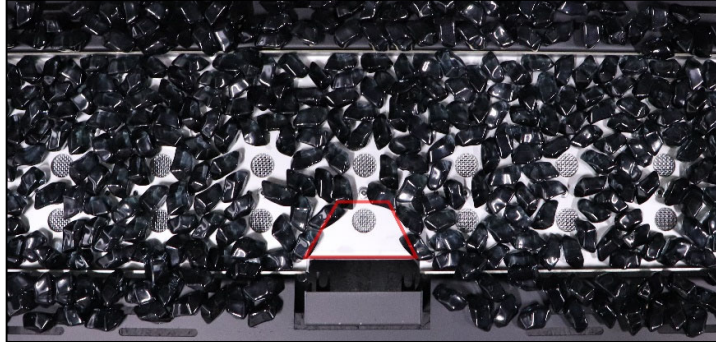

- Do not use the hood to support media. This could cause overheating of the thermocouple.
- Keep the media away from the edges and the glass.
- Do not overfill the media tray. Keep 20% of the tray open to allow for air flow.

Glass Media Placement

- When placing glass media, put only a single layer, and do not pack down. Once the media is placed, go back and move the glass back slightly to open the ports:

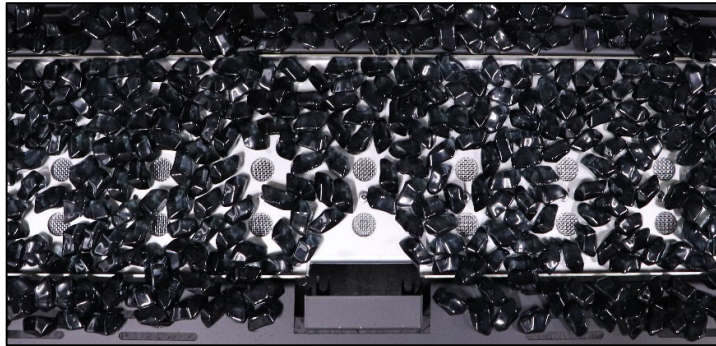

Stone Media Placement

- When placing stone media, use the space left by the round shape to leave the ports open.

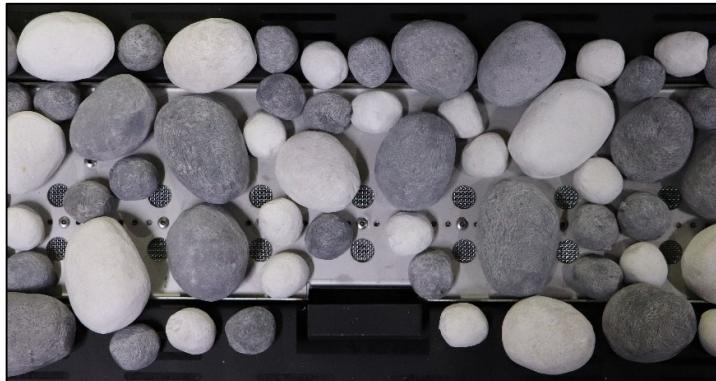

Log Media Placement

- Place the logs carefully to block as few ports as possible. If a log is placed over a port, block the port with a “coin” to keep the flame from creating soot on the media or to manipulate the look of the flame.

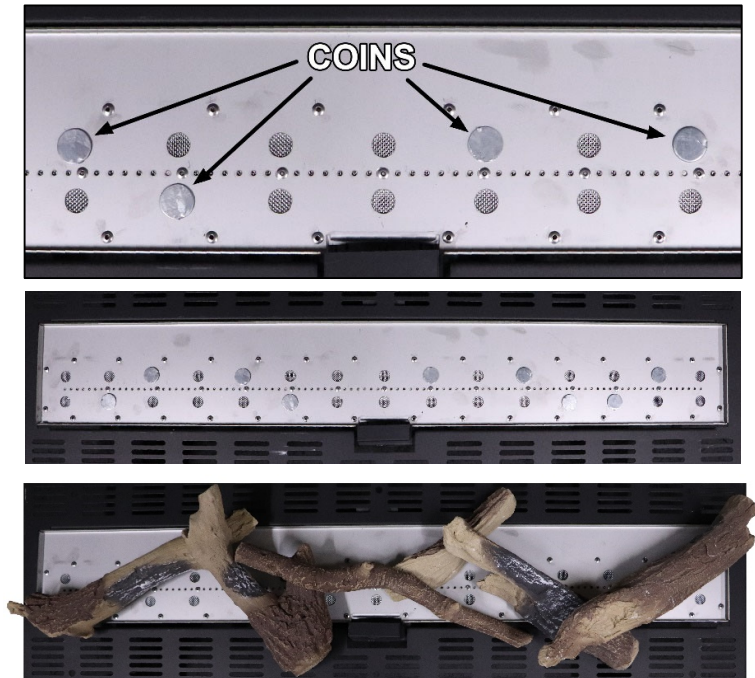

- Block as few ports as possible, and no more than 30% of total ports. Do **NOT** block ports that are next to one another.
- When combining both logs and glass, it is recommended to place the logs (and coins if needed) first, and then to spread the glass according to the instructions given above.



Operation

⚠ WARNING – Read these instructions carefully before lighting the fireplace.

Four operation options are available for use with the fireplace:

- 10-Button Remote Control Handset (default option, always included with the fireplace)
- Puck Handset (optional accessory)
- Wall Switch (optional accessory)
- MyFire Application (optional accessory)

! IMPORTANT: The 10-Button remote control handset is always included with the fireplace regardless of which operation option is chosen. DO NOT DISCARD. The 10-Button remote must be kept within 26 feet of the fireplace at all times.

! NOTES:

- Wiring of valve and receiver must be completed before starting ignition. Failure to do so could damage the electronics.
- If operating the fireplace without an AC adapter, battery replacement is recommended at the beginning of each heating season.
- Fireplaces with double glass, power vent, and/or interior lighting features must operate using the AC Adapter and therefore will not operate during a power failure.
- Only the Mertik Maxitrol AC Adapter is permitted for use with the fireplace. Use of other adapter brands can render the system inoperable. The handsets, receivers, wall switches are not interchangeable with other electronics.
- Batteries must be kept within their recommended temperature limits (32°F to 131°F).

→ 10-Button Remote Control Handset

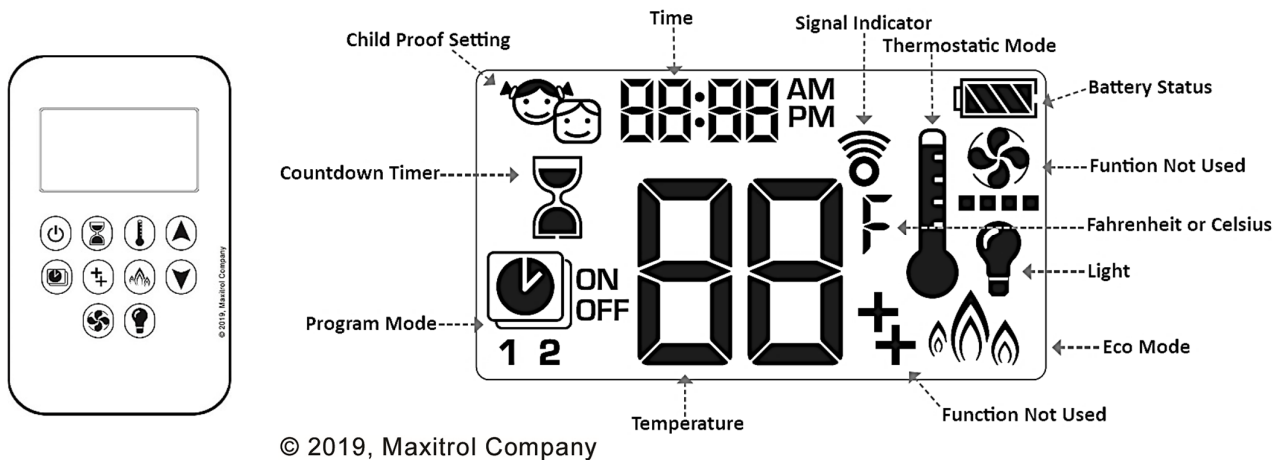

Control Option	Radio Frequency	Power Supply	
10-Button Handset	918.0 MHz (U.S. & Canada)	2 x 1.5V AAA batteries (quality alkaline recommended)	Replace batteries after 2 years or when low battery indicator appears on handset display

IMPORTANT: For safety/communication purposes, 10-button handset must be located within 26 feet of the receiver.

! NOTE: Any device that functions using the same radio frequency as the handset will be affected when handset is in use.

Operating Instructions

Instructions for operating the 10-Button Handset are shown below. For more in-depth instructions, please refer to the “Homeowner’s Fireplace Operation Manual” or “Remote Operation Instructions”.

! NOTE: Some options on the remote may not be available for all fireplaces.

Turning the Fireplace On

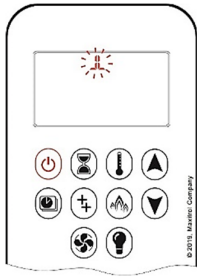

1. Press the  button until you hear continuous beeping, and a blinking series of lines confirms the start sequence has begun; release buttons.
2. Main gas flows once pilot ignition is confirmed.
3. The system automatically goes into Manual Mode after main burner ignition.

NOTE: When pilot ignition is confirmed, motor turns automatically to maximum flame height.

NOTE: If the Timer function has been set and the fireplace is manually turned on, the Timer function will need to be reset.

Turning the Fireplace Off





1. Press the  button to turn the fireplace off.

NOTE: The fireplace may be turned on again after the OFF icon stops flashing.

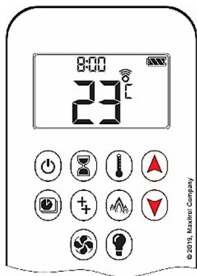
Flame Height Adjustment



1. To increase flame height, press and hold the  button to desired flame height.
2. To decrease flame height, or to set fireplace to pilot flame only, press and hold the  button.

→ Puck Handset

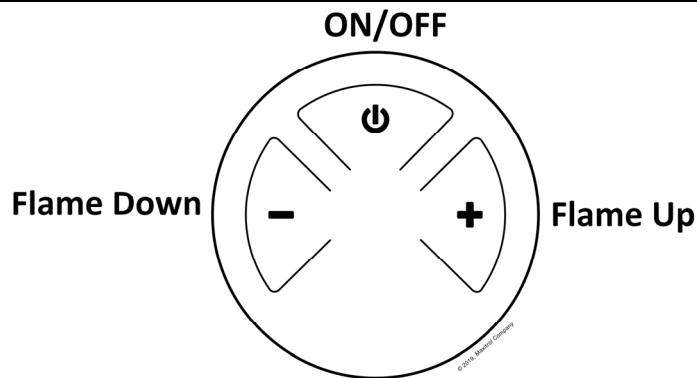

Control Option	Radio Frequency	Power Supply	
Puck Handset	918.0 MHz (U.S. & Canada)	2 x 1.5V AAA batteries (quality alkaline recommended)	Replace batteries after 2 years or when low battery indicator appears on handset display

IMPORTANT: For safety/communication purposes, Puck handset must be located within 26 feet of the receiver.

NOTE: Any device that functions using the same radio frequency as the handset will be affected when handset is in use.

Operating Instructions

Instructions for operating the Puck Handset are shown below.

Turning the Fireplace On/Off

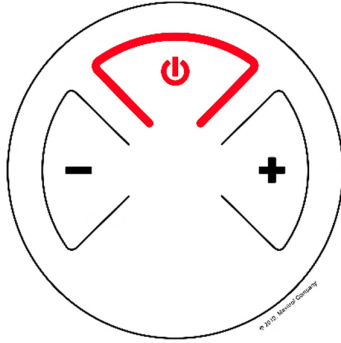

ON:

- Firmly press and hold the  button until two short beeps confirms the start sequence has begun; release button.

OFF:

- Firmly press the  button.

Increase/Decrease Flame Height

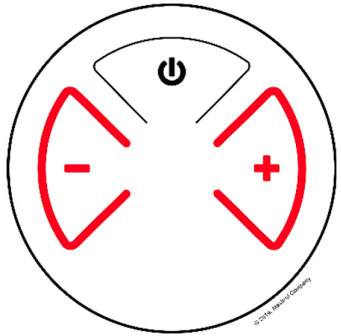

INCREASE:

- To increase flame height, press and hold **+** button.

DECREASE:

- To decrease flame height, press and hold **-** button.
- Holding the **-** button long enough sets the fireplace to pilot flame (Standby Mode).

Designated Flame Settings

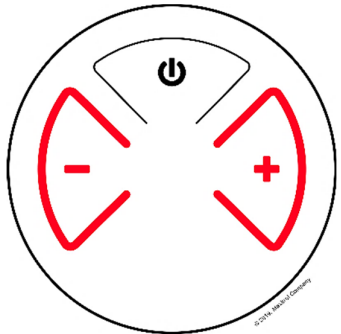

DESIGNATED LOW FLAME SETTING

- To go to designated low flame setting, double-click **-** button.

 **NOTE:** Flame goes to High Flame before going to Low Flame.

DESIGNATED HIGH FLAME SETTING

- To go to designated high flame setting, double-click **+** button.

Wall Switch

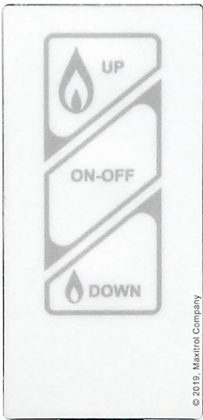

Control Option	Radio Frequency	Power Supply
Wall Switch	N/A	N/A

IMPORTANT: For safety/communication purposes, the 10-button handset must be located within 26 feet of the receiver.

Operating Instructions

Turning the Fireplace On/Off



ON/OFF

ON: Press and hold the **ON-OFF** button until two short beeps confirms the start sequence has begun; release button.

OFF: Press the **ON-OFF** button.

Flame Height Adjustment

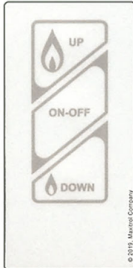

Flame Up

Flame Down

INCREASE: To increase flame height, press and hold  (up flame) button.

DECREASE: To decrease flame height, press and hold  (down flame) button.

Holding the  (down flame) button long enough sets the fireplace to pilot flame (Standby Mode).

→ MyFire App

The MyFire app requires the Wi-Fi kit to operate with the fireplace. The Wi-Fi kit does not automatically come with the fireplace and must be ordered.



IMPORTANT: For safety/communication purposes, the 10-button handset must be located within 26 feet of the receiver.

To download the MyFire app, search “MyFire” at the Apple App Store or Google Play.

Operating Instructions

For setup and operating instructions of the MyFire app, see the Homeowner’s Fireplace Operation Manual, or visit the Ortol website or www.myfireapp.com.

MyFire Wi-Fi Box

The MyFire Wi-Fi router box provides the Wi-Fi connection that allows the MyFire App to operate the fireplace. This part is included with the optional Wi-Fi kit. Wi-Fi kit does not automatically come with the fireplace and must be ordered.



Part	Radio Frequency	Power Supply	Wireless Communication
MyFire Wi-Fi Box	2.4 GHz	Connects to Receiver	WPA2 authentication AES 256-bit encryption security Compatible with IEEE 802.11 b/g/n

Fireplace Maintenance

General Maintenance

All servicing, maintenance, interior cleaning and handling of the fireplace, parts and glass must be performed by an authorized Ortal dealer service technician only.

Servicing

- Turn off the gas and electricity **BEFORE** servicing the fireplace.
- It is recommended that a routine inspection is performed at the beginning of each heating season.
- When removing glass from multisided fireplaces, only one side of glass can be removed at a time. Glass must be re-installed before removing glass from a different side.

Burner and Vent Inspections

- Periodic checks should be made of the burner for correct position and condition. Visually check the flame of the burner, making sure that the flames are steady.
- The vent system must be inspected before use. Annual inspection must be scheduled to ensure the flow of combustion and ventilation air.

Submerged Parts

- Do not use the fireplace if any part has been under water, or if you suspect that it may have been under water. The Ortal dealer service technician must inspect and, if necessary, replace any parts of the control system and any gas controls which have been under water.

Handling the Glass

Inner glass panel is 5mm ceramic glass. Exterior double glass panel is 3/16" tempered glass. Tempered glass can be sourced locally if replacement becomes necessary. Ceramic glass must be provided by Ortal.

- When removing glass from multisided fireplaces, only one side of glass can be removed at a time. Glass must be re-installed before removing glass from a different side.
- **NEVER** operate the fireplace without the glass properly secured in place.
- Only an Ortal certified installer is authorized to remove the glass. Glass must be removed using an 8-inch glass-handling suction cup. Lower the glass to rest in a safe place to prevent damage to the glass edges.

Cleaning the Fireplace

- Only an Ortal dealer service technician can open the fireplace to clean interior surfaces.
- **ALWAYS** turn off the gas valve before cleaning.
- Do **NOT** clean when hot. Make sure fireplace has had time to cool prior to cleaning any surface or component, interior or exterior.
- Keep the fireplace clean by brushing and/or vacuuming at least once a year. This can only be performed by an Ortal dealer service technician.
- When removing glass from multisided fireplaces, only one side of glass can be removed at a time. Glass must be re-installed before removing glass from a different side.
- Clean the glass when it starts to look cloudy. Use a damp cloth for cleaning the fireplace and the door.
- Verify correct operation after servicing.

Maintenance Frequency and Equipment Checklist

- Under normal circumstances, the factory recommendation is to have the fireplace serviced at least once a year. Fireplaces meeting the following conditions should have more frequent service:
 - Fireplaces installed in commercial/public spaces should be serviced every 3 months.
 - Fireplaces installed in climates near the ocean or in other settings where corrosion buildup is more likely should be serviced every 6 months.
- Thermocouple Maintenance:
 - The thermocouple should be replaced annually or as needed in all commercial installations, and in any residential fireplace where the fireplace is operated for an average of 10 hours or more per day.
 - For all other installations, the thermocouple should be replaced every three years or as needed.

© Ortal 2022
Version 1.0, July 2022
SKU: KPMANSATSV1.0

Ortal USA
2152 Citygate Drive, Columbus, OH 43219
T: (818) 238-7000 | F: (818) 678-0541
info@ortalheat.com | www.ortalheat.com