

Ortal's Deep Dive Series

Topic: Heat Releases

Written by Ortal's Architect & Designer Resource Team

One of the main differences between an Ortal built-in fireplace and many other direct vent gas fireplace brands is the requirement for an opening on the wall above the fireplace called a **Heat Release**. The heat release is a fundamental element of **Cool Wall Technology** that allows for an unparalleled level of design flexibility with a gas fireplace. Understanding the why and how of the heat release can significantly simplify the design process.

Cool Wall Technology

Passive Cool Wall Technology is a result of how (1) the fireplace is engineered and (2) the way the wall around the fireplace is built. An Ortal Cool Wall fireplace is designed to allow convective heat to rise off the firebox and move toward the ceiling of the fireplace wall cavity (chase). By creating an opening (heat release) in the wall near the chase ceiling, a pathway is provided for the heat to move from the chase and into the room. This method dramatically impacts the temperatures of the wall above the fireplace.

Distance Above Viewing Area	Fireplace <u>WITHOUT</u> Cool Wall	Fireplace <u>WITH</u> Cool Wall
0"-6" above viewing area	280°F - 380°F (138°C - 193°C)	100°F - 120°F (38°C - 49°C)
6"-12" above viewing area	195°F - 300°F (91°C - 149°C)	90°F - 110°F (32°C - 43°C)
12" above viewing area	145°F - 250°F (63°C - 121°C)	80°F - 90°F (27°C - 32°C)

This significant reduction of temperature allows for an unsurpassed degree of design flexibility. For example, with an Ortal fireplace:

- A TV can be as close as 4 inches from the top of the viewing area.
- There are no restrictions for finishes. Combustible material can be brought right to the fireplace viewing area with no threat of damage to the finish.

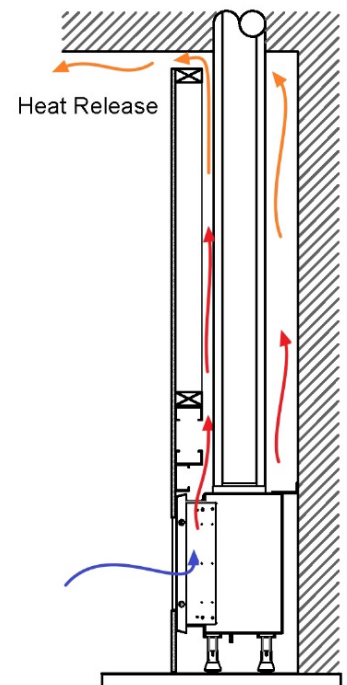

Cool Wall Technology

Heat Release Requirements

There are 3 main components to designing an effective heat release: size, location, and orientation.

- **Size:** The size requirement is given as a minimum square inch amount that varies by model (listed in the corresponding installation manual). The actual dimensions do not matter (until it impacts orientation) as long as the specified amount of heat can flow into the room.
- **Location:** A heat release must go to a conditioned space. It cannot be on an exterior wall. In addition, the heat release must be located within a maximum of 6 inches from the top of the fireplace chase. It can extend down as low as desired.

The Reason: Cool Wall Technology is a passive system, relying entirely on how heat moves naturally, and heat rises. It will only tolerate a small amount of downward movement. If the heat release is too low on the wall, the heat will initially bypass the heat release and pool at the chase ceiling, creating a heat pocket. This is why a heat release opening must be as close as possible to the ceiling of the chase.

If you prefer the heat release to be lower, you can achieve this by putting a false ceiling inside the chase at the desired location.

- **Orientation:** The heat release may be oriented horizontally (wider than it is tall) across the wall, or vertically (taller than it is wide) down the wall. If the height of a horizontal heat release exceeds $\frac{1}{3}$ of the width, it is then considered a vertical heat release.

Because heat moves more effectively out of a horizontal heat release than a vertical one, a vertical heat release must be 30% larger.

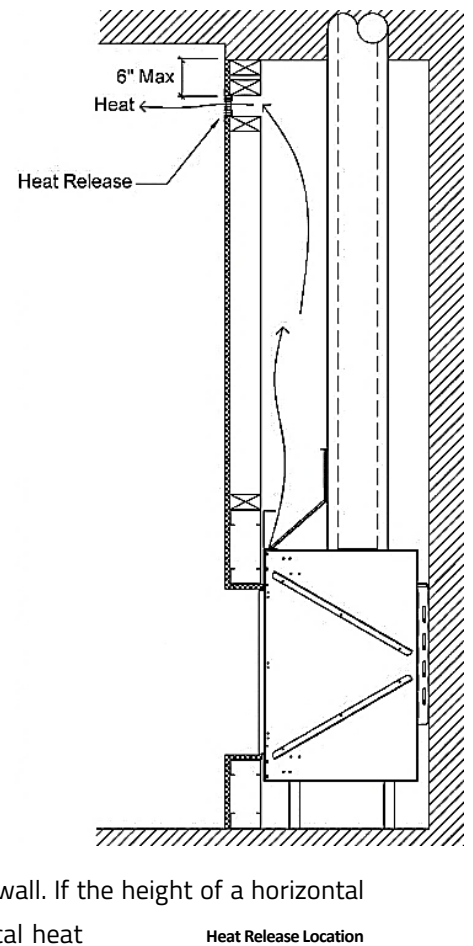

Fireplace Model Number	Horizontal Heat Release	Vertical Heat Release
25-31 40-75	Minimum 50 sq. in. of free air space	Minimum 65 sq. in. of free air space
44-51 110-130	Minimum 120 sq. in. of free air space	Minimum 156 sq. in. of free air space
60-77 150-200	Minimum 200 sq. in. of free air space	Minimum 260 sq. in. of free air space
98 250	Minimum 250 sq. in. of free air space	Minimum 325 sq. in. of free air space

Examples of Heat Release Designs

There are many ways to design a heat release. As long as the requirements listed on the previous page are met, the number of heat release designs are effectively limitless.

- **Louver/Grille:** A custom louver or grille can be an elegant solution when designed thoughtfully. It is important to keep in mind that the heat release size requirement is **not** the same as the grille dimensions. The clear free space of the grille openings must allow for the minimum square inch requirement as listed in the applicable Ortal installation manual.



- **Gap:** A gap is a defined opening in the wall. The dimensions of the gap can exactly meet the minimum square inch size requirement. A gap can be a good fit for a room with a more modern aesthetic.



- **Reveal:** A reveal is a popular choice for a heat release design. It allows for the cleanest and most unobstructive aesthetic. A gap is left between the entire chase and the room ceiling, creating a shadow-line effect.

Note: An opening less than $\frac{3}{4}$ " high is too restrictive for air flow and is therefore not permitted.



- **Vertical Heat Release:** A vertical slot, louver, or grille can be a clean, effective way to hide the heat release from the front view of the fireplace. The total heat release square inch requirement can be located on just one side, or it can be split between the two sides.

Reminder: A vertical heat release must be 30% larger than a horizontal heat release.



- **Heat Release on a Short Chase:** On most models, the chase above the fireplace can be built as short as 12 inches above the fireplace viewing area. In this instance, there are two ways to approach the heat release; it can be at the front edge or on the top of the chase.



- **Hidden Heat Release:** There are ways to strategically position the heat release so it is not visible from the viewpoint of the fireplace. For example, if your fireplace is on an interior wall, the heat release can be located on a side wall of the chase or in the wall directly behind the fireplace.



- **Floating Wall:** A floating wall can offer a creative alternative for incorporating the heat release and air intake (for double glass barrier) into one seamless design.



- **Extended Location:** This type of heat release is located at an extended distance from the fireplace viewing area. In this design, internal blocking is used to direct the heat toward the heat release opening to prevent it from pooling at the chase ceiling. This heat release design requires approval from Ortal to ensure the exact requirements are met.



- **Heat Release from Ceiling:** In instances where the heat release in the chase conflicts with architectural elements, such as crown moulding or design intent of fireplace, the heat release can be located in the ceiling. This type of heat release design also requires approval from Ortal to ensure the exact requirements are met.

